

# Owner's Manual

# **POWERTEC**<sup>®</sup>

# **Miter Saw Stand with Wheels**

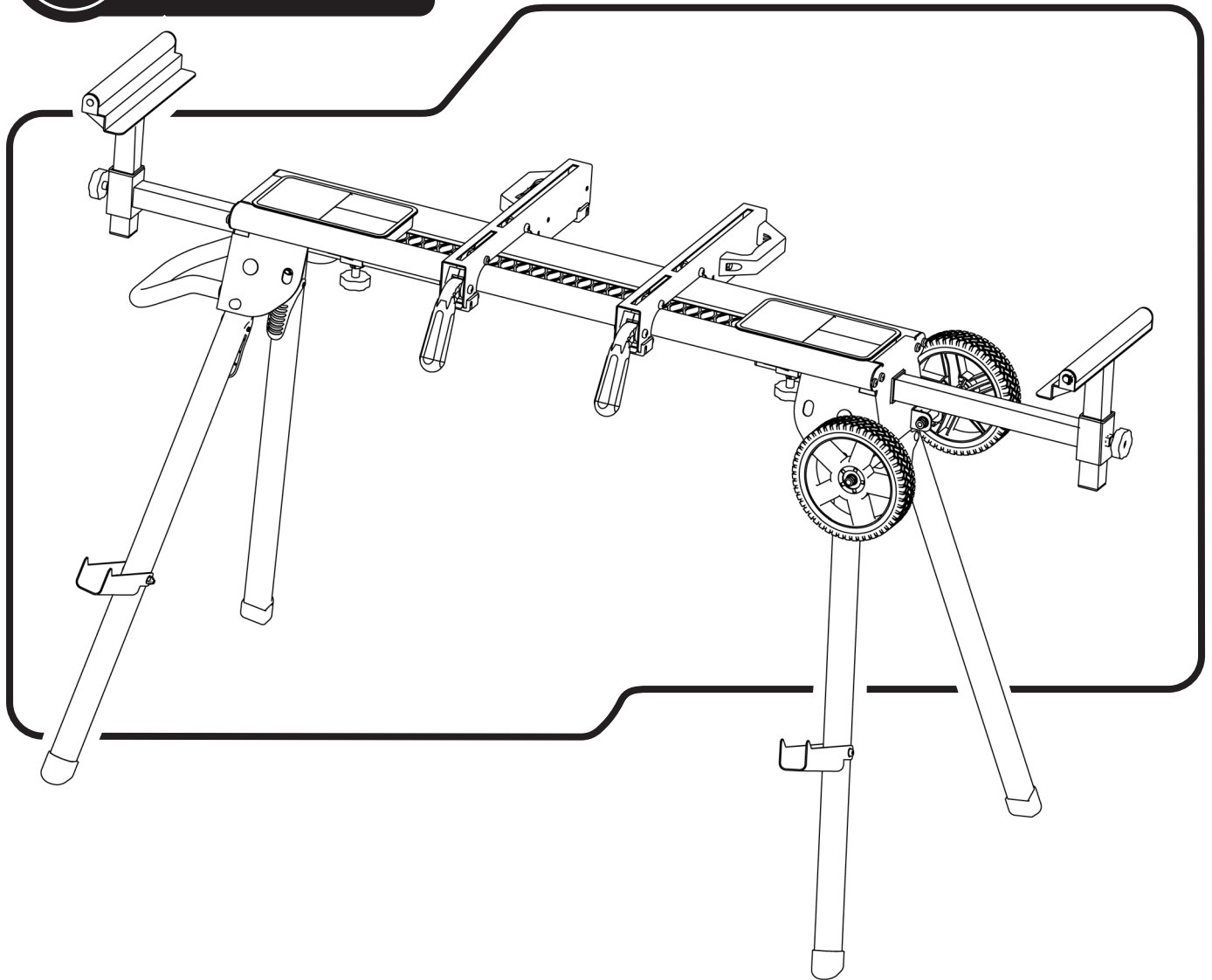

Visit us on the web at [www.powertecproducts.com](http://www.powertecproducts.com)



You will need this manual for safety instructions, operating procedures, and warranty. Put it and the original sales invoice in a safe, dry place for future reference.

## TABLE OF CONTENTS

SECTION PAGE



**SAFETY RULES / WARNINGS** 3



**CONTENTS** 4



**ASSEMBLY** 4-5

- Unpacking
- Tools Needed
- Assemble Handle
- Unfold Work Legs
- Assemble Wheels
- Assemble Roller Bars/Extension Bars and Locking Knobs
- Mounting the Miter Saw (not included)



**OPERATION** 6

- Adjust Quick Release Brackets
- Roller Bars/Extension Bars Adjustment
- Material Supports
- Transporting



**MAINTENANCE** 7

- General Maintenance



**PARTS LIST & ILLUSTRATION** 7



**WARRANTY** 8

## PRODUCT SPECIFICATIONS

- Height .....33-1/4" (846 mm)
- Extended Width ..... 42"-65-1/4" (1067-1657 mm)
- Maximum Load Capacity** ..... 330 lbs (150 kg)
- Net Weight ..... 29.3 lbs. (13.3 kg)
- Gross Weight ..... 33.7 lbs. (15.3 kg)

**⚠ WARNING**

For your own safety, read all of the rules and precautions before operating equipment.

**⚠ WARNING**

Always follow proper operating procedures as defined in this manual even if you are familiar with use of this miter saw stand or any tool used with this stand. Remember that being careless for even a fraction of a second can result in severe personal injury.

You must be familiar with the use of any tool or accessory used with this miter saw stand. The supplier cannot be held responsible for any accident, injury or damage incurred while using this stand with any tool.

**⚠ WARNING**

Some dust created by operation of power tool contains chemicals known to the State of California to cause cancer, birth defects or other reproductive harm. To reduce your exposure to these chemicals, work in a well ventilated area and work with approved safety equipment. Always wear OSHA/NIOSH approved, properly fitting face mask or respirator when using such tools.

**⚠ WARNING**

Do not use the Miter Saw Stand until it is completely assembled and you have read and understood this entire operating manual.

**⚠ WARNING**

Do not modify this Miter Saw Stand and/or use it for any application other than that for which it was designed.

**ELECTRICAL SAFETY**

- Power tool plugs must match the outlet. Never modify the plug in any way. Do not use any adapter plugs with grounded power tools. Unmodified plugs and matching outlets will reduce the risk of electric shock.
- Avoid body contact with grounded surfaces, such as pipes, radiators, ranges, and refrigerators. There is an increased risk of electric shock if your body is grounded.
- Do not expose power tools to rain or wet conditions. Water entering a power tool will increase the risk of electric shock.
- Do not abuse the cord. Never use the cord for carrying, pulling, or unplugging the power tool. Keep the cord away from heat, oil, sharp edges, or moving parts. Damaged or entangled cords increase the risk of electric shock.
- When operating a power tool outdoors, use an extension cord suitable for outdoor use. Use of a cord suitable for outdoor use reduces the risk of electric shock. If operating a power tool in a damp location is unavoidable, use a ground fault circuit interrupter (GFCI) protected supply. Use of a GFCI reduces the risk of electric shock.

**SAFETY FOR WORK STAND**

- Do not attempt to assemble or operate your miter saw stand until you have read the safety instructions in this section.
- Only use your miter saw stand on a hard, dry and flat surface.
- Keep your work area clean and well lit. Cluttered or dark areas invite accidents.
- Do not overreach. Keep proper footing and balance at all times.

**⚠ WARNING**

This product was designed to be used as a Miter Saw Stand. Do not overload. The maximum load capacity for the Miter Saw Stand is **330 lbs (150 kg)**.

- Store properly. Do not store the miter saw stand outdoors or in a damp location.
- Do not stand or climb on miter saw stand. It could tip over, causing serious injury.
- Do not permit children to use the miter saw stand unsupervised. It is not a toy.
- Be sure all locking pins are in the set-up position holes before using your miter saw and miter saw stand.
- Take care when moving the stand, especially when a miter saw is mounted.
- Dress properly. Do not wear loose clothing or jewelry. Keep your hair, clothing and gloves away from moving parts. Loose clothes, jewelry or long hair can be caught in moving parts. Always wear non-slip footwear. Tie back long hair. Roll long sleeves above the elbow.
- Always firmly attach the miter saw used with this stand. Do not attempt to use the miter saw on the miter saw stand until the miter saw is fastened firmly.
- Be aware of tipping. When a large piece is cut from one end of a job, the remaining piece may be heavy enough to tip the miter saw stand. Always ensure the workpiece is well supported.
- Always keep all guards in place. Be sure all power tool guards are in good working order and are in proper adjustment and alignment.
- Always keep your hands away from the cutting area.

**⚠ CAUTION**

Think safety! Safety is a combination of operator common sense and alertness at all times when tools are being used.

**⚠ WARNING**

Do not attempt to operate tool until it is completely assembled according to the instructions.

**⚠ WARNING**

To avoid serious injury, turn off and unplug any equipment before attaching or changing accessories or adjusting Miter Saw Stand position.

**SAVE ALL WARNINGS AND INSTRUCTIONS  
FOR FUTURE REFERENCE**

# CONTENTS

## UNPACKING Refer to Figure 1

Check for shipping damage. Check immediately whether all parts and accessories are included.

| ITEM            | DESCRIPTION   | QTY   |
|-----------------|---|-------|
| A               | Miter Saw Stand   | 1     |
| B               | Quick Release Mounting Brackets   | 2     |
| C               | Roller Bars   | 2     |
| D               | Locking Knobs, plain threads (roller bars)                                | 2     |
| E               | Locking Knobs, threads with plastic cap (extension bar)                   | 2     |
| F               | Wheels  | 2     |
| G               | Handle  | 1     |
| <b>HARDWARE</b> |   |       |
| H               | Locking Nut M8 (wheels)   | 4     |
| I               | Washer Ø8 [wheels (4), handle (2)]  | 6     |
| J               | Washer Ø12 (wheels)   | 2     |
| K               | Axle  | 2     |
| L               | Bolt (handle)   | 2     |
| M               | Lock Washer (handle)  | 2     |
| N               | Miter Saw Mounting Hardware (mounting bolt, washer, lock washers and nut) | 4 ea. |

Figure 1

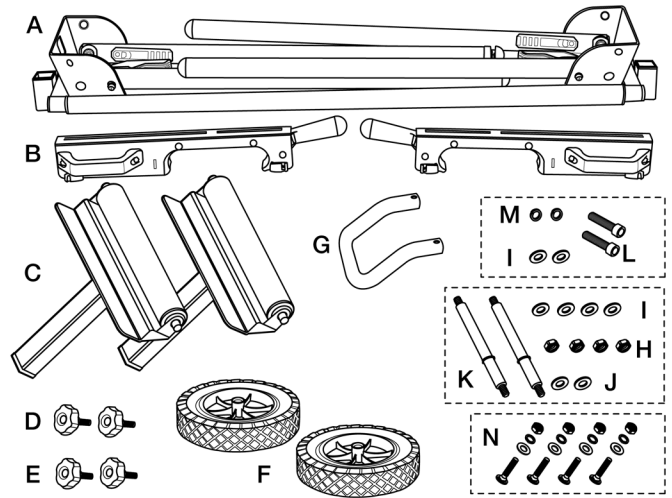

## TOOLS NEEDED (Not Included)

- Phillips screwdriver
- 13 mm wrench or socket

### **⚠️ WARNING**

Do not use the Miter Saw Stand until it is completely assembled. Read and understand entire Miter Saw Stand operating manual and operating manual for the miter saw being used with this Miter Saw Stand.

# ASSEMBLY

### **⚠️ WARNING**

Do not use the Miter Saw Stand for scaffolding or as a ladder. Make sure to securely tighten all fasteners before using. Maximum capacity is 330 lbs (150 kg). Power tools on the Miter Saw Stand should not exceed a combined overall height of 60" (152.4 cm) from the floor.

## ASSEMBLE HANDLE

Figure 2

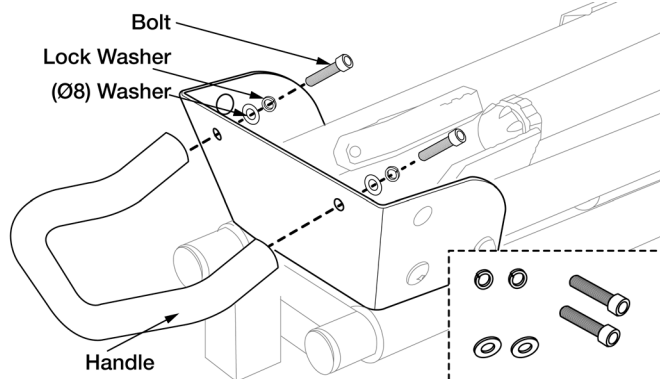

- Secure handle to frame with hardware supplied.

## UNFOLD THE WORK LEGS

- Place Miter Saw Stand on a flat surface with the folded legs facing up.
- Depress the release lever and rotate the leg until it clicks and locks into the open position. Repeat for each leg.

### **⚠️ CAUTION**



Pinch Hazard. To avoid pinching or crushing fingers, Keep hands away from areas where legs lock.

Figure 3

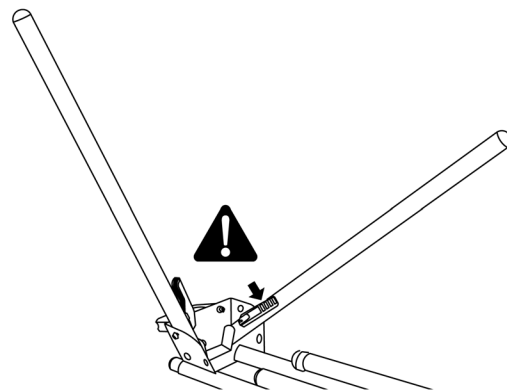

- Position Miter Saw Stand upright on a flat surface.

## ASSEMBLE WHEELS

- Slide Axle through Axle Bracket—turn Axle until machined end fits into inside bracket hole. Place one small (Ø8) Washer and Nut onto Axle. Tighten Nut.

**NOTE:** The axle has a retaining ring on one end and is machined to fit the axle bracket hole on the other end, make sure the machined end is inserted into the axle bracket first.

- Slide one large (Ø12) Washer and Wheel (F) onto Axle. Secure in place with small (Ø8) Washer and Nut. Tighten Nut. **NOTE:** Raised hub goes to the inside.
- Repeat with other wheel.

Figure 4

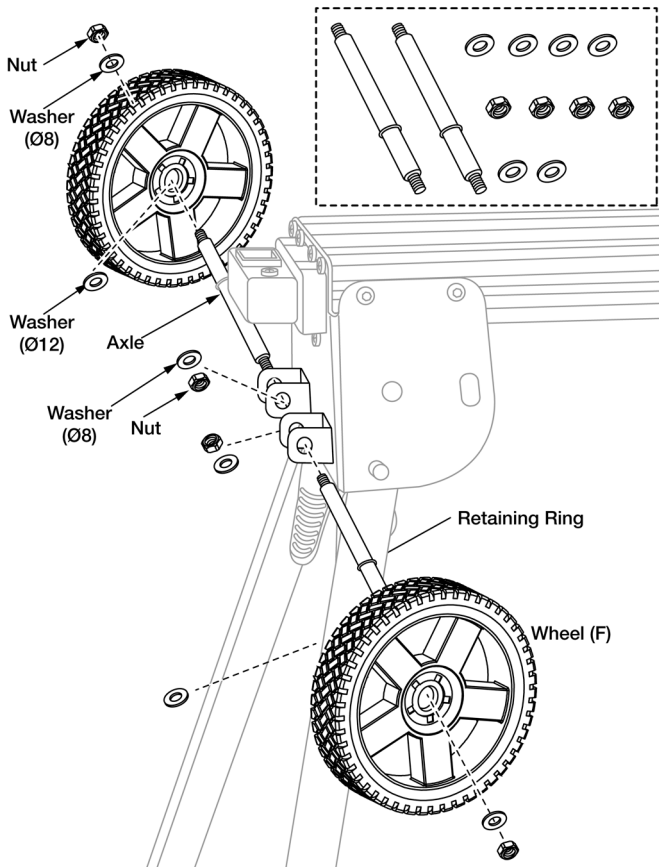

## ASSEMBLE ROLLER BAR/ EXTENSION BAR LOCKING KNOBS

- Place the roller arms into the roller bar supports, slide up and down to desired location and secure in place with locking knobs (plain threads).
- Assemble locking knobs (threads with plastic cap) to the bottom of the frame as shown.

Figure 5

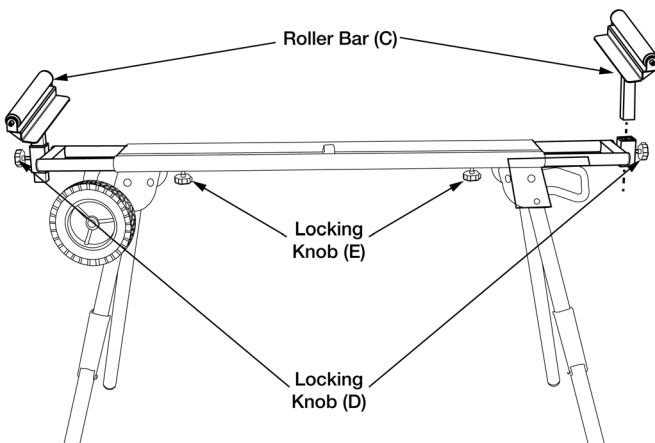

## MOUNTING THE MITER SAW

Refer to Figures 6-7



Risk of accidental start up and serious personal injury. Unplug miter saw before attaching it to miter saw stand.



Risk of serious personal injury. Always make sure the miter saw is fully supported and securely attached to a level work surface. Make sure the miter saw stand is located on a flat surface.



**Do not mount a table saw on this miter saw stand.** Aggressive feeding of sheet materials into a table saw could cause the stand to tip over.

**NOTE:** This Miter Saw Stand is to be used with miter saws having four mounting holes in a rectangular pattern.

Figure 6

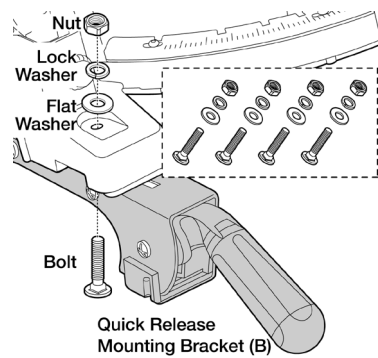

Mount the miter saw to Quick-release Mounting Brackets (B) using the supplied hardware (mounting bolt, washer, lock washers and nut) as shown.

- The Quick-release Mounting Brackets hook onto the Miter Saw Stand Frame.
- Using the handles on the Quick-release Mounting Brackets, lift the miter saw and position the Quick-release Mounting Brackets onto the Miter Saw Stand as shown in Figure 7.

**NOTE:** Saw not shown to allow visibility of the rails and brackets.

Figure 7

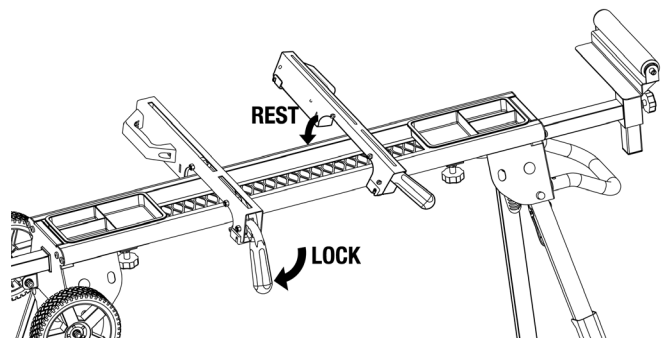

- Lower the saw into place and press the locking levers down to lock the mounting brackets into place.





## OPERATION

### FEATURES

Figure 8

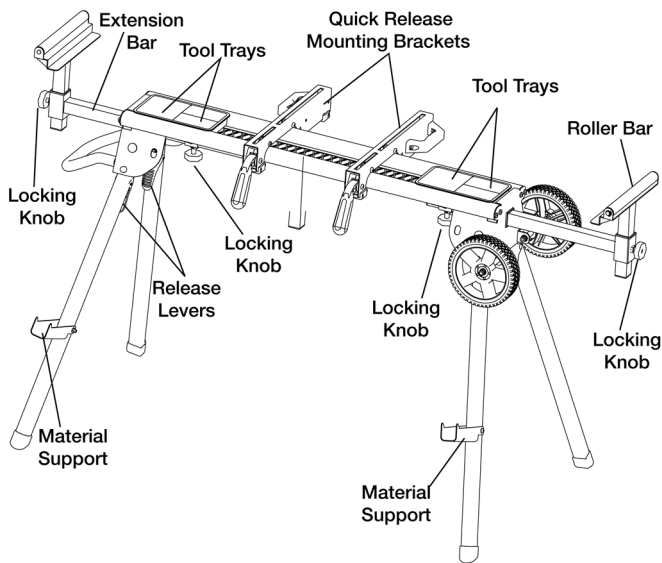

### **WARNING**

Do not use the miter saw stand for scaffolding or as a ladder. Make sure to securely tighten all fasteners before using. Maximum capacity is 330 lbs (150 kg). Power tools on the miter saw stand should not exceed a combined overall height of 60" (152.4 cm) from the floor.

**NOTE:** For your convenience this stand is equipped with tool trays and a mesh bottom to help prevent accidental dropping of tools.

### ADJUST QUICK RELEASE BRACKET

- The quick release mounting brackets must be secure on the miter saw stand. If adjustment is needed:
- Turn the adjusting nut on the adjustment screw clockwise to tighten the clamping tension.
- Turn the adjusting nut on the adjustment screw counterclockwise to loosen the clamping tension.

Figure 9

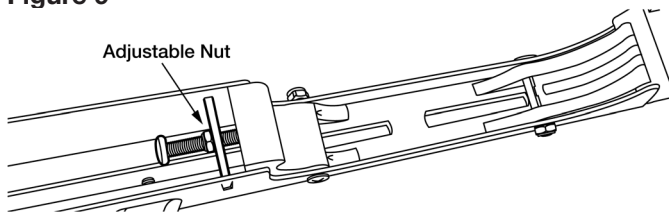

### ROLLER BARS AND EXTENSION BAR ADJUSTMENT Refer to Figure 8

The extension bars move in and out to properly support the workpiece.

The roller bars are used as directional rollers or with the extension bars as stationary stop guides.

- Loosen the locking knobs, slide the extension bar in or out to the required position, tighten the locking knobs.
- Loosen the locking knobs, slide the roller bars up and down to desired location, tighten the locking knobs.

### MATERIAL SUPPORTS Refer to Figure 8

Fold the material supports out to stack extra material for easy excess.

### TRANSPORTING

### **WARNING**

Risk of unsafe operation. Ensure proper footing and use caution when rolling the miter saw stand to prevent tipping or loss of balance.

- Loosen the locking knobs, slide the two extension bars in, tighten the locking knobs
- Lift up on the end of the miter saw stand with wheels.
- While holding the stand with one hand, squeeze the release levers and fold up the two suspended legs. The legs will lock into place.
- Lower the stand until the wheels rest on a flat surface.
- Using the handle, tilt the other end of the miter saw stand up and transfer the weight to the wheels.
- Squeeze the release levers and fold up the remaining two legs. The legs will lock into place.
- Holding the handle, carefully lower the stand to the ground.
- To move the stand, use handle to lift and tilt the miter saw stand onto the wheels. Move miter saw stand as shown.

Figure 10

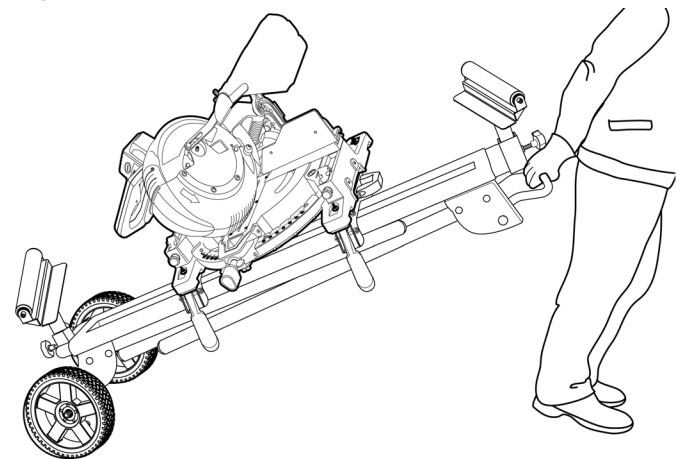

## MAINTENANCE

### GENERAL MAINTENANCE

### **WARNING**

When servicing, use only identical replacement parts. Use of any other parts may create a hazard or cause product damage. To ensure safety and reliability, all repairs should be performed by a qualified service technician.

### **WARNING**

Keep the miter saw stand dry, clean, and free from oil and grease. Always use a clean cloth when cleaning. Never use brake fluids, gasoline, petroleum based products or any strong solvent to clean the miter saw stand. Chemicals can damage, weaken or destroy plastic which may result in serious personal injury.

# MITER SAW STAND PARTS LIST



| Key# | Part#     | Description                | Specifications | Qty |
|------|-----------|----------------------------|----------------|-----|
| 1    | MT4008001 | Body Tube                  |                | 2   |
| 2    | MT4008002 | Storage Box                | PP             | 2   |
| 3    | MT4008003 | Legs Fixing Housing        |                | 1   |
| 4    | MT4008004 | Nylon Fixing Nut           | M8             | 4   |
| 5    | MT4008005 | Flat Washer                | Φ8             | 10  |
| 6    | MT4008006 | Flat Washer                | Φ12            | 2   |
| 7    | MT4008007 | C Clip                     | Φ12            | 2   |
| 8    | MT4008008 | Axle                       |                | 2   |
| 9    | MT4008009 | Pan Head Screws            | M6*12          | 8   |
| 10   | MT4008010 | Square Tube End Caps       | PP             | 4   |
| 11   | MT4008011 | Wheels                     |                | 2   |
| 12   | MT4008012 | Bolt                       | M6*14          | 8   |
| 13   | MT4008013 | Legs Fixing Housing        |                | 1   |
| 14   | MT4008014 | PH Screw                   | M8*16          | 2   |
| 15   | MT4008015 | Split Washer               | 8              | 2   |
| 16   | MT4008016 | Handle                     |                | 1   |
| 17   | MT4008017 | Rivet                      | 5*10           | 16  |
| 18   | MT4008018 | Locking Knob               | M8*15          | 2   |
| 19   | MT4008019 | Extension Tube Fixing Part | PP             | 2   |
| 20   | MT4008020 | Steel Net                  |                | 1   |
| 21   | MT4008021 | Mounting Locking Handle    |                | 2   |
| 22   | MT4008022 | Cam Block                  | ABS            | 2   |
| 23   | MT4008023 | FH Shoulder Screw          | 7*45           | 2   |
| 24   | MT4008024 | FH Shoulder Screw          | M6*45          | 4   |
| 25   | MT4008025 | Hex Bolt                   | M6*20          | 4   |
| 26   | MT4008026 | Mounting Carrying Handle   |                | 2   |
| 27   | MT4008027 | Spring Pin                 | Φ5*45          | 4   |
| 28   | MT4008028 | FH Shoulder Screw          | M6*35          | 2   |
| 29   | MT4008029 | M6 Nut                     | M6             | 10  |

| Key# | Part#     | Description                       | Specifications | Qty |
|------|-----------|-----------------------------------|----------------|-----|
| 30   | MT4008030 | Saw Mounting Bracket              |                | 2   |
| 31   | MT4008031 | Mounting Bracket End Cap          | PE             | 4   |
| 32   | MT4008032 | Nylon Fixing Nut                  | M6             | 8   |
| 33   | MT4008033 | Rear Clamp Jaw                    | PP             | 2   |
| 34   | MT4008034 | Front Clamp Jaw                   | PA6+GF20%      | 2   |
| 35   | MT4008035 | Split Washer                      | 6              | 6   |
| 36   | MT4008036 | Flat Washer                       | Φ6             | 8   |
| 37   | MT4008037 | Carriage Bolt                     | M6*60          | 4   |
| 38   | MT4008038 | Roller                            |                | 2   |
| 39   | MT4008039 | Work Support Welding Part         |                | 2   |
| 40   | MT4008040 | End Cap                           |                | 4   |
| 41   | MT4008041 | Slotted Screw                     | 10*34.5        | 4   |
| 42   | MT4008042 | End Cap                           | 30*30          | 4   |
| 43   | MT4008043 | Work Support Welding Part         | PP M8*15       | 2   |
| 44   | MT4008044 | Extension Tube                    |                | 2   |
| 45   | MT4008045 | PH Screw                          | M6*8           | 2   |
| 46   | MT4008046 | Hexagon Socket Button Head Screws | M6*46          | 2   |
| 47   | MT4008047 | Material Support                  |                | 2   |
| 48   | MT4008048 | Legs                              |                | 2   |
| 49   | MT4008049 | C Clip                            | 6              | 4   |
| 50   | MT4008050 | Nylon Fixing Nut                  | M10            | 4   |
| 51   | MT4008051 | Carriage Bolt                     | M10*45         | 4   |
| 52   | MT4008052 | Locking Pin                       |                | 4   |
| 53   | MT4008053 | Rivet                             | 6*44           | 4   |
| 54   | MT4008054 | Quick Release Leg Lock Lever      | PP             | 4   |
| 55   | MT4008055 | Legs                              |                | 2   |
| 56   | MT4008056 | Feet End Cap                      |                | 4   |

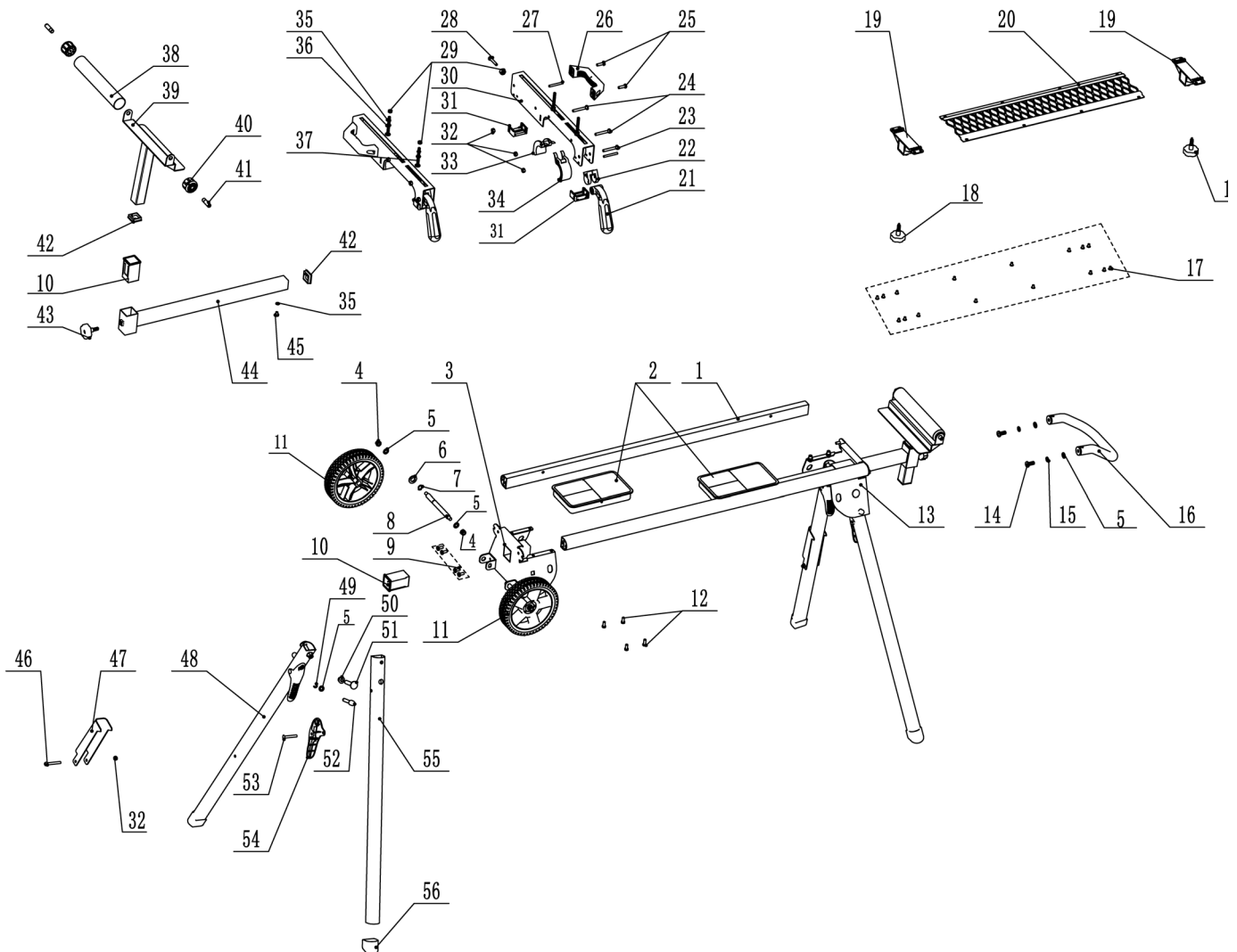

Thank you for investing in a **POWERTEC**® power tool. This product has been designed and manufactured to meet high quality standards and is guaranteed for domestic use against defects in workmanship or material for a period of 12 months from the date of purchase. This guarantee does not affect your statutory rights.

**SOUTHERN TECHNOLOGIES LLC. BENCH TOP AND STATIONARY POWER TOOL  
LIMITED 1 YEAR WARRANTY AND 30-DAY SATISFACTION GUARANTEE POLICY**

**POWERTEC** products are designed and manufactured by **Southern Technologies LLC**. All warranty communications should be directed to **Southern Technologies LLC** by calling 847-780-6120 (toll free), 9 AM to 5 PM, Monday through Friday, US Pacific Time.

**30- DAY SATISFACTION GUARANTEE POLICY**

During the first 30 days after the date of purchase, if you are dissatisfied with the performance of this **POWERTEC** tool for any reason, you may return the tool to the retailer from which it was purchased for a full refund or exchange. You must present proof of purchase and return all original equipment packaged with the original product. The replacement tool will be covered by the limited warranty for the balance of the one year warranty period.

**LIMITED ONE YEAR WARRANTY**

This warranty covers all defects in workmanship or materials in this **POWERTEC** tool for a one year period from the date of purchase. This warranty is specific to this tool. **Southern Technologies, LLC** reserves the right to repair or replace the defective tool, at its discretion.

**HOW TO OBTAIN SERVICE**

To obtain service for this **POWERTEC** tool you must return it, freight prepaid, to **POWERTEC**. You may call (toll free) 847-780-6120 for more information. When requesting warranty service, you must present the proof of purchase documentation, which includes a date of purchase. **POWERTEC** will either repair or replace any defective part, at our option at no charge to you. The repaired or replacement unit will be covered by the same limited warranty for the balance of one year warranty period.

**WHAT IS NOT COVERED**

This warranty applies to the original purchaser at retailer and may not be transferred.

This warranty does not cover consumable items such as saw blades, knives, belts, discs, cooling blocks, and sleeves. This warranty does not cover required service and part replacement resulting from normal wear and tear, including accessory wear.

This warranty does not cover any malfunction, failure or defect resulting from:

- 1) Misuse, abuse, neglect and mishandling not in accordance with the owner's manual.
- 2) Damage due to accidents, natural disasters, power outage, or power overload.
- 3) Commercial or rental use.
- 4) Alteration, modification or repair performed by persons not recommended by **POWERTEC**.

**DISCLAIMER**

To the extent permitted by applicable law, all implied warranties, including warranties of MERCHANTABILITY or FITNESS FOR A PARTICULAR PURPOSE, are disclaimed. Any implied warranties, that cannot be disclaimed under state law are limited to one year from the date of purchase. **Southern Technologies LLC**. is not responsible for direct, indirect, incidental or consequential damages. Some states do not allow limitations on how long an implied warranty lasts and/or do not allow the exclusion or limitation of incidental or consequential damages, so the above limitations may not apply to you. This warranty gives you specific legal rights, and you may also have other rights which vary from state to state. Southern Technologies LLC., makes no warranties, representations, or promises as to the quality or performance of its power tools other than those specifically stated in this warranty.

**POWERTEC**®

Southern Technologies LLC • Chicago • IL 60606