

POWERTEC®

Precision Miter Gauge



WARNING

For your own safety, read the machine's instruction manual before using any accessory. Failure to heed these warnings may result in serious personal injury and damage to the tool and the accessory.

- Before using the Precision Miter Gauge, read and follow all instructions and safety information provided.
- Always keep hands clear of the blade, cutter, sanding disc/belt.
- Before making adjustments to the Precision Miter Gauge, turn off the power, allow the blade, cutter or sanding disc/belt to come to a complete stop and unplug the machine.
- Ensure handle and lock knob are tight before using.
- Before turning on the power after adjustments, ALWAYS verify there is a safe clearance between the blade and fence.

UNPACKING CONTENTS

NOTE: Check for shipping damage. Check immediately whether all parts and accessories are included.

ITEM	DESCRIPTION	QTY
A	Miter Gauge	1
B	Handle	1
C	Washer for Handle	1
D	5/16" Round Knobs	2
E	T-Bolt 5/16"-18x3/4"	2
F	Extra Expansion Discs (Retain for future use)	4
G	M4 Screws (for Expansion Discs)	4
H	3 mm Hex Wrench	1
I	2.5 mm Hex Wrench	1

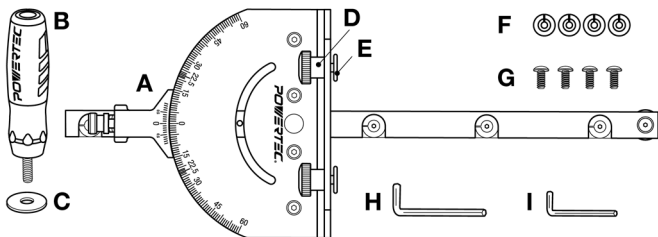

WARNING

Risk of accidental starting and serious personal injury. Unplug the machine before attaching the Precision Miter Gauge.

ASSEMBLY Refer to Figures 1, 2

No additional tools needed.

NOTE: This miter gauge is equipped with a Locking Plunger with spring loaded pin. The most commonly used angles are notched with positive stops 0°, 15°, 22.5°, 30°, 45° and 60°. To set or change the angles see **TO USE** on page 4.

Figure 1

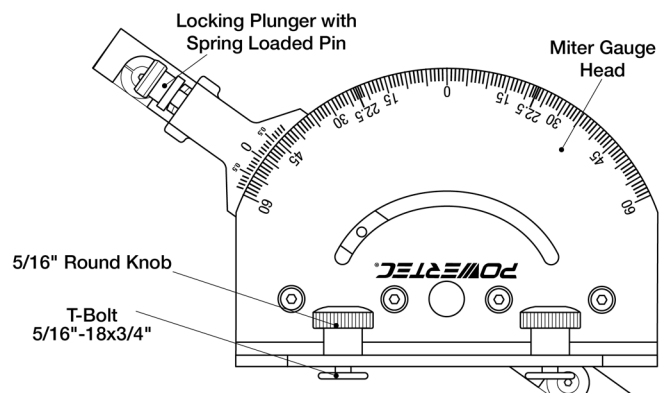

See Figure 2. Place washer onto handle threads and thread the handle onto the guide bar. Tighten handle.

Figure 2

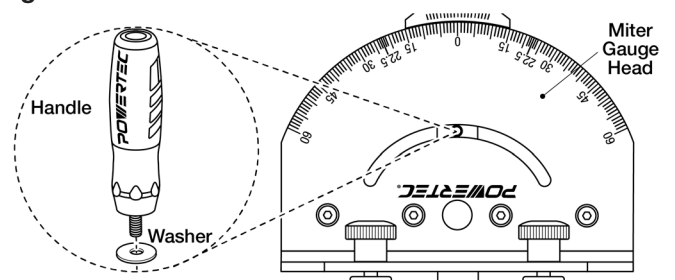

SETTING THE GAUGE TO 90° See Figure 3

NOTE: The Miter Gauge arrives factory calibrated. For convenience, a Fence (not included) can also be used to verify perpendicularity to the miter bar.

1. Align both the Miter Gauge Head and Indexer to 0°. Lock the Adjustment Plunger.
2. Use a square to verify that the miter bar and miter gauge face are perpendicular.

Figure 3

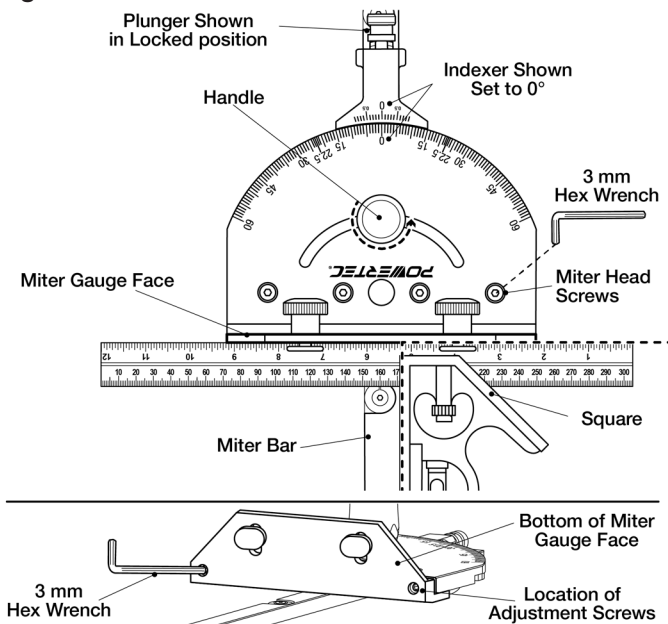

If not square or requires resetting:

Use the included 3 mm hex wrench to loosen the four screws on top of the miter head. Back out the two screws on bottom of miter gauge face. Use a square to set the face perpendicular to the miter bar. Re-tighten the four screws on the top of the miter gauge. Run the two screws, on the bottom face of the miter bar, in until they **just touch** the miter gauge head. Use a square to verify the face is still perpendicular and did not shift.

NOTE: Once the miter gauge face is square to the bar, no other adjustment is required. If by chance the workpiece is not square, use a square to square the miter gauge face directly to the blade or follow the instructions supplied with the machine to square the machine's miter slot to the blade.

FITTING MITER GAUGE TO MITER SLOT

See Figures 4, 5. If the tool is equipped with a T-slotted miter slot, use the 3 mm hex wrench (included) to ensure the screw holding the miter bar plate is tight. If the tool is not equipped with a T-slotted miter slot, remove the plate. Save this part.

Figure 4

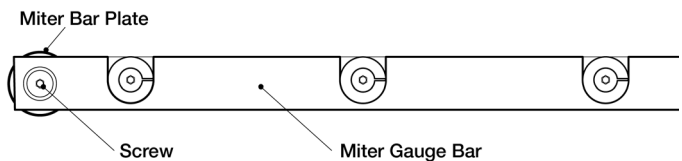

Place the miter bar into the miter slot on the saw table and check for side movement. If the miter gauge guide bar moves freely through the miter slot and has no side-to-side play, no adjustment is needed.

If adjustment is needed:

Use the four expansion discs located on the top of the miter bar to adjust any side movement. Use the 2.5 mm hex wrench (included) to tighten the screws until all side motion is removed. Turn the screws clockwise to tighten the fit and counterclockwise to loosen the fit. Ensure the bar slides freely in the miter slot.

Figure 5

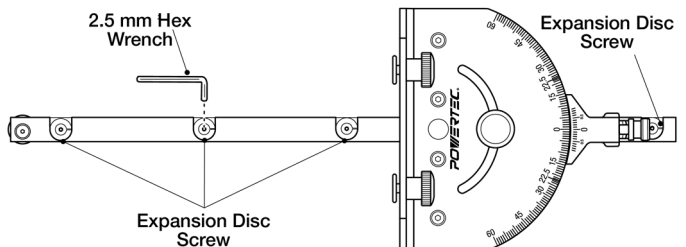

TO SQUARE THE MITER GAUGE FACE

See Figures 6, 7. The miter bar features an adjustment screw that allows the miter gauge face to be set perpendicular to the table.

To Check:

1. Set the indexing lever to 0° and engage the spring loaded pin.
2. Tighten the handle and place the miter bar into the miter slot.
3. Use a square to check the perpendicularity of the face to the table. If square, no adjustment is needed.

NOTE: Check can be made with or without a fence installed.

Figure 6 (Shown without Fence)

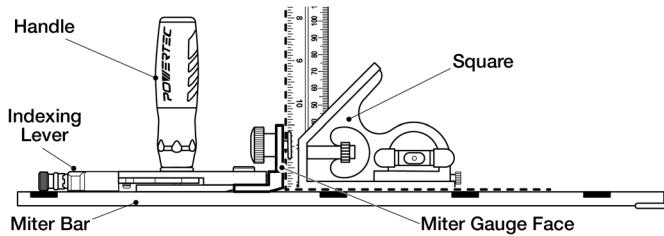

If adjustment is needed: See Figure 7

1. Remove the miter bar from the miter table slot and flip over.
2. Loosen the handle.
3. Locate the adjustment screw on the bottom of the miter bar, adjust with the 3 mm hex wrench (included).

NOTE: If the gap is at the top of the miter gauge face, tighten the adjustment screw. If the gap is at the bottom of the miter gauge face, loosen the adjustment screw.

4. Tighten the handle and recheck. Repeat until square.

Figure 7

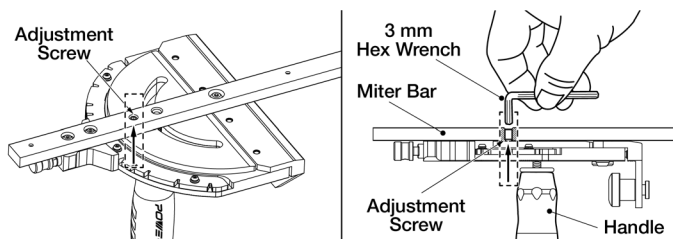

INSTALL ONTO A FENCE (Not included)

This Precision Miter Gauge is designed to work with POWERTEC and DuBois Fences (not included). It can also be used as a conventional Miter Gauge on various other fences.

Figures 8-9 Shown using POWERTEC 71768 Fence (Sold separately)

1. Remove Fence Lock Knob. Loosen the two 5/16" Round Knobs on the Miter Gauge and slide the T-bolts into the Fence slot.

Figure 8

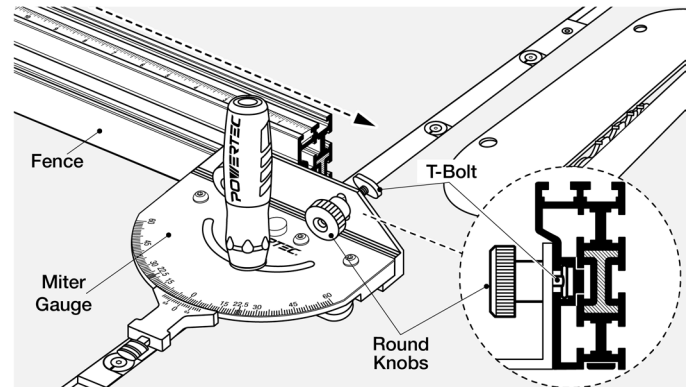

2. Tighten 5/16" Round Knobs on Miter Gauge. Reinsert Fence Lock Knobs and tighten to secure in position.

Figure 9

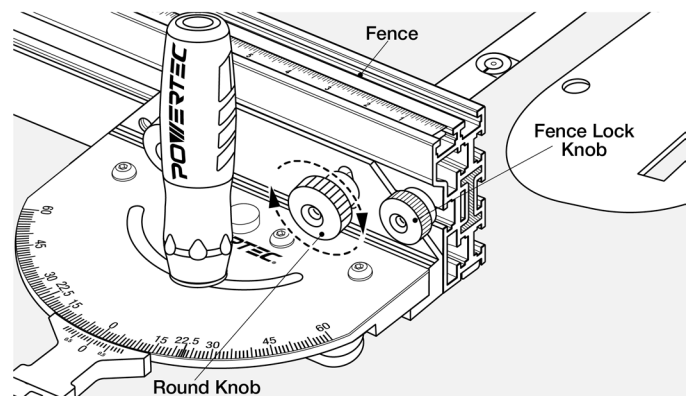

TO USE

See Figure 10. Loosen the Handle. To unlock the Adjustment Plunger pull and twist left (counter clockwise). Release. Plunger is now in neutral position. The Miter Gauge will now move freely side-to-side.

Figure 10

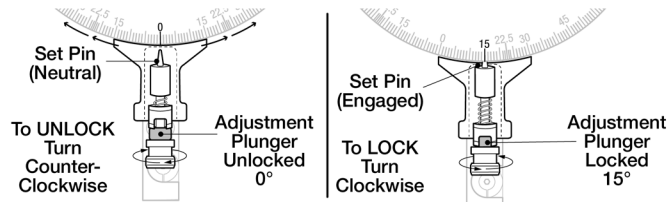

CAUTION

Always keep Adjustment Plunger in UNLOCKED position when moving set pin to any location. Failure to do so may result in damage to the Miter Gauge.

If desired angle is a positive stop, pull Adjustment Plunger and twist right (clockwise). Allow set pin to drop into notch of the desired positive stop. Release the spring loaded plunger to secure into place. Tighten the handle.

If the desired angle is not a positive stop, maneuver Miter Gauge to desired angle and tighten the handle.

For Example:

The protractor scale on the Miter Gauge head acts like a Vernier scale and precise angles can be set.

1. Loosen the handle and unlock the adjustment plunger.
2. Figure 11 shows the gauge set to 25.3 degrees. Zero is past the 25 degree mark and the upper and lower scales line up 3 marks past zero on the lower scale.
3. In Figure 12, zero is past the 18 degree mark and the upper and lower scales line up 7 marks past zero on the lower scale.
4. When the angle is set, tighten the handle.

Figure 11

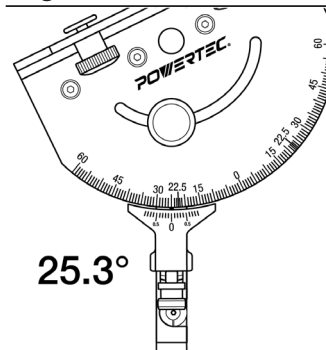
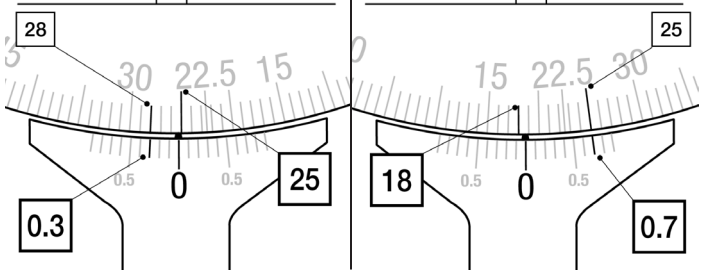
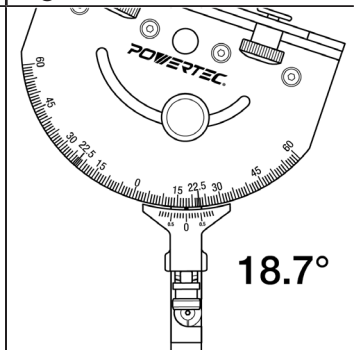

Figure 12



WARNING

When servicing, use only identical replacement parts. Use of any other parts may create a hazard or cause product damage. To ensure safety and reliability, all repairs should be performed by a qualified service technician.

WARNING

Keep the Precision Miter Gauge dry, clean, and free from oil and grease. Always use a clean cloth when cleaning. Never use brake fluids, gasoline, petroleum-based products or any strong solvent to clean the Precision Miter Gauge. Chemicals can damage, weaken or destroy plastic which may result in serious personal injury.

Visit us on the web at www.powertecproducts.com



Put these instructions and the original sales invoice in a safe, dry place for future reference.

Southern Technologies, LLC • Chicago, IL 60606