



Precision Miter Gauge Fence System



UNPACKING CONTENTS

NOTE: Check for shipping damage. Check immediately whether all parts and accessories are included.

ITEM	DESCRIPTION	QTY
A	Miter Gauge	1
B	Telescoping Fence, 3" x 1-3/8" x 20" with 12" Movable Scale	1
C	3" Fence Flip Stop with Pointer	1
D	Extra Expansion Discs (Retain for future use)	4
E	M4 Screws (for Expansion Discs)	4
F	5/16" Round Knobs	2
G	T-Bolt 5/16"-18x3/4"	2
H	3 mm Hex Wrench	1
I	2.5 mm Hex Wrench	1
J	Handle	1
K	Washer for Handle	1

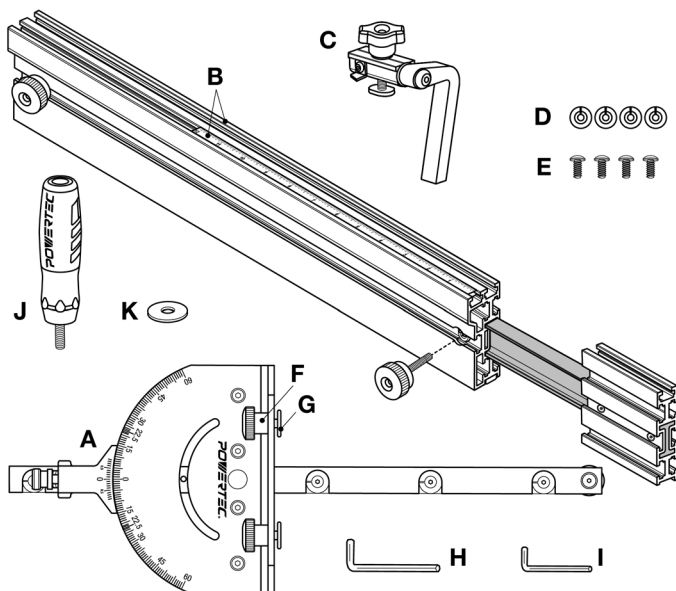

WARNING

For your own safety, read the machine's instruction manual before using any accessory. Failure to heed these warnings may result in serious personal injury and damage to the tool and the accessory.

- Before using the Precision Miter Gauge Fence System, read and follow all instructions and safety information provided.
- Always keep hands clear of the blade, cutter, sanding disc/belt.
- Before making adjustments to the Precision Miter Gauge Fence System, turn off the power, allow the blade, cutter or sanding disc/belt to come to a complete stop and unplug the machine.
- Ensure handle and lock knob are tight before using.
- Before turning on the power after adjustments, ALWAYS verify there is a safe clearance between the blade and fence.

WARNING

Risk of accidental starting and serious personal injury. Unplug the machine before attaching the Precision Miter Gauge Fence System.

ASSEMBLY Refer to Figures 1, 2

NOTE: This miter gauge is equipped with a Locking Plunger with spring loaded pin. The most commonly used angles are notched with positive stops 0°, 15°, 22.5°, 30°, 45° and 60°. To set or change the angles see **TO USE** on page 4.

Figure 1

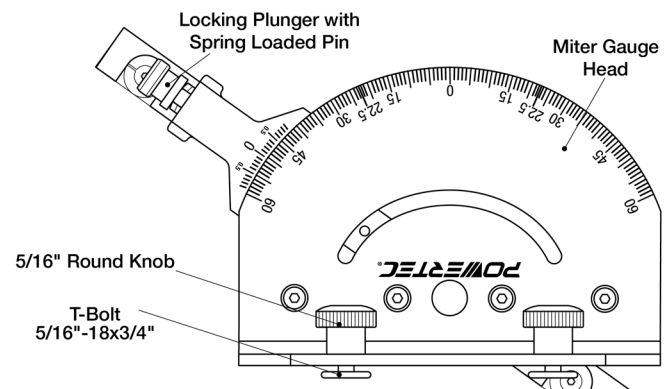

See Figure 2. Place washer onto handle threads and thread the handle onto the guide bar. Tighten handle.

Figure 2

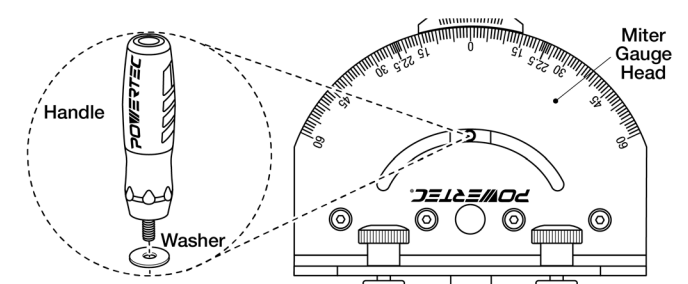

SETTING THE GAUGE TO 90° See Figure 3

NOTE: The Miter Gauge arrives factory calibrated. For convenience, the assembled Fence can also be used to verify perpendicularity to the miter bar.

1. Align both the Miter Gauge Head and Indexer to 0°. Lock the Adjustment Plunger.
2. Use a square to verify that the miter bar and miter gauge face are perpendicular.

Figure 3

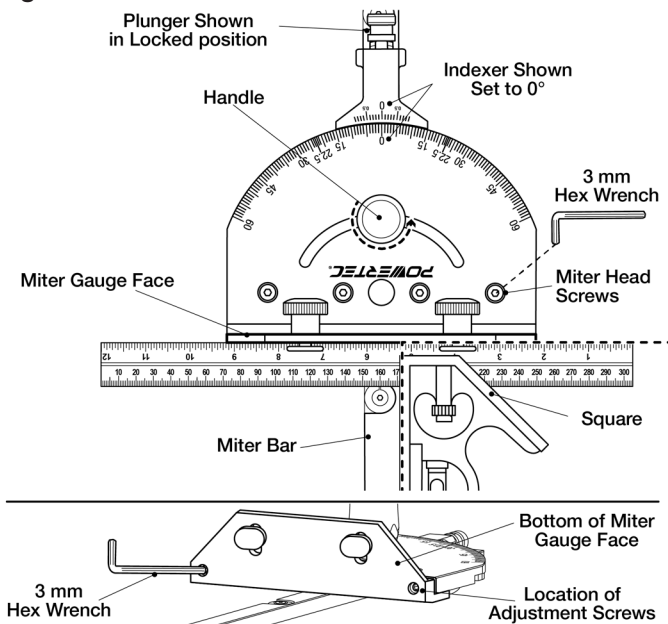

If not square or requires resetting:

Use the included 3 mm hex wrench to loosen the four screws on top of the miter head. Back out the two screws on bottom of miter gauge face. Use a square to set the face perpendicular to the miter bar. Re-tighten the four screws on the top of the miter gauge. Run the two screws, on the bottom face of the miter bar, in until they **just touch** the miter gauge head. Use a square to verify the face is still perpendicular and did not shift.

NOTE: Once the miter gauge face is square to the bar, no other adjustment is required. If by chance the workpiece is not square, use a square to square the miter gauge face directly to the blade or follow the instructions supplied with the machine to square the machine's miter slot to the blade.

FITTING MITER GAUGE TO MITER SLOT

See Figures 4, 5. If the tool is equipped with a T-slotted miter slot, use the 3 mm hex wrench (included) to ensure the screw holding the miter bar plate is tight. If the tool is not equipped with a T-slotted miter slot, remove the plate. Save this part.

Figure 4

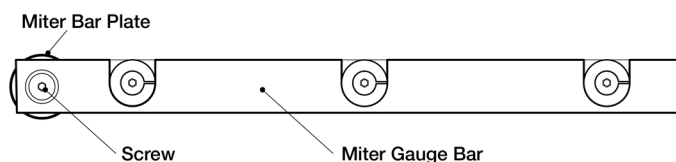

3. Place the miter bar into the miter slot on the saw table and check for side movement. If the miter gauge guide bar moves freely through the miter slot and has no side-to-side play, no adjustment is needed.

If adjustment is needed:

Use the four expansion discs located on the top of the miter bar to adjust any side movement. Use the 2.5 mm hex wrench (included) to tighten the screws until all side motion is removed. Turn the screws clockwise to tighten the fit and counterclockwise to loosen the fit. Ensure the bar slides freely in the miter slot.

Figure 5

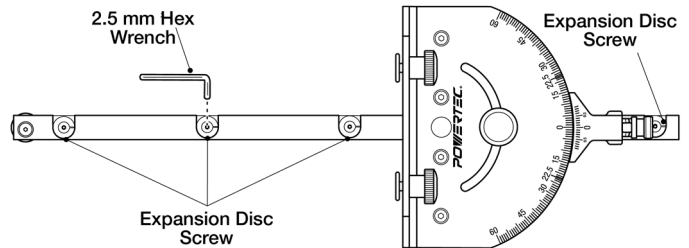

TO SQUARE THE MITER GAUGE FACE

See Figures 6, 7. The miter bar features an adjustment screw that allows the miter gauge face to be set perpendicular to the table.

To Check:

1. Set the indexing lever to 0° and engage the spring loaded pin.
2. Tighten the handle and place the miter bar into the miter slot.
3. Use a square to check the perpendicularity of the face to the table. If square, no adjustment is needed.

NOTE: Check can be made with or without Fence installed.

Figure 6 (Shown without Fence)

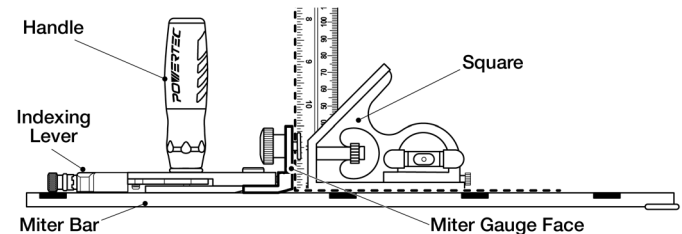

If adjustment is needed: See Figure 7

1. Remove the miter bar from the miter table slot and flip over.
2. Loosen the handle.
3. Locate the adjustment screw on the bottom of the miter bar, adjust with the 3 mm hex wrench (included).

NOTE: If the gap is at the top of the miter gauge face, tighten the adjustment screw. If the gap is at the bottom of the miter gauge face, loosen the adjustment screw.

4. Tighten the handle and recheck. Repeat until square.

Figure 7

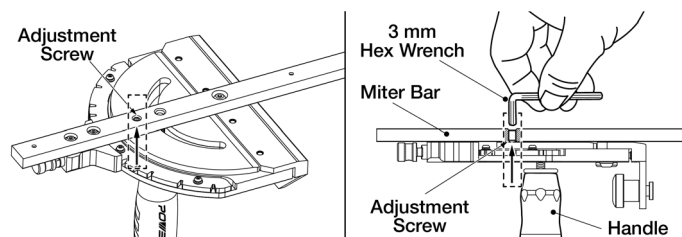

INSTALL THE FENCE

Figure 8

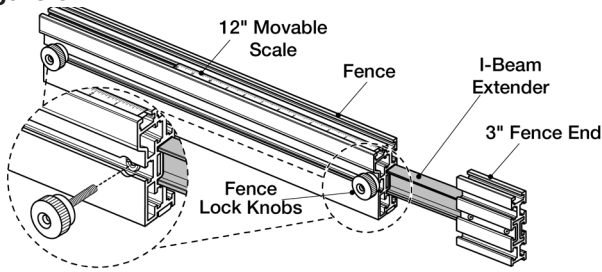

1. See Figure 9. To expand the Fence and/or switch Fence position, loosen the two Lock Knobs and pull the 3" Fence End out to desired length and secure Lock Knobs. The I-Beam Extender with 3" Fence End allows an additional 17" extension.
2. The I-Beam Extender can be used on either end of the Fence. To change sides, loosen the Lock Knob, remove the 3" Fence End with I-Beam Extender. Locate the I-beam profile on the other end of the Fence and insert I-Beam into the Fence. Tighten Knobs.

Figure 9

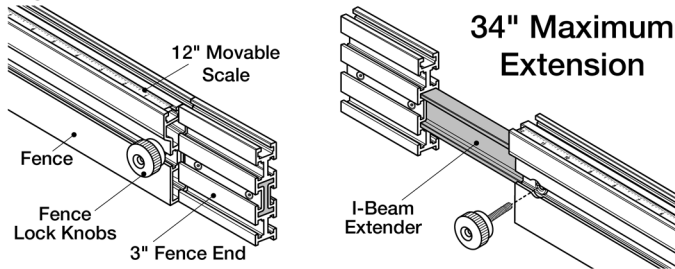

3. See Figure 10. Remove Fence Lock Knob. Loosen the two 5/16" Round Knobs on the Miter Gauge and slide the T-bolts into the Fence slot.

Figure 10

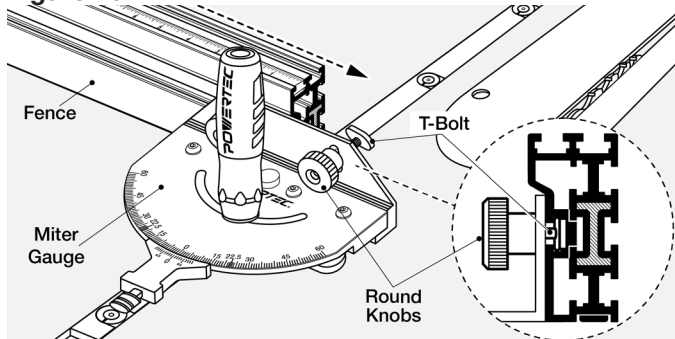

4. See Figure 11. Insert I-Beam Extender with 3" Fence End. Set to desired length. Tighten 5/16" Round Knobs on Miter Gauge. Reinsert Fence Lock Knobs and tighten to secure I-Beam Extender in position.

Figure 11

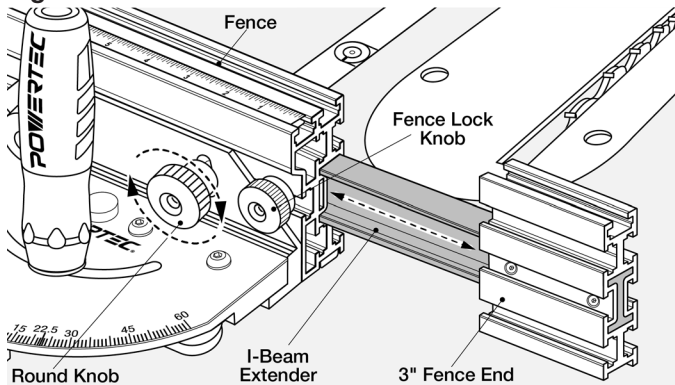

INSERT THE FLIP STOP

1. See Figure 12. Slide the T-Bolt into the slot on the top of the Fence or 3" Fence End (shown with 3" Fence End). Position the arm as needed and tighten the Adjustment Knob.

NOTE: When clamped, the unique cylindrical shape of the body wedges into the top of the T-Track allowing the flip stop to work with different size of T-Tracks and eliminates slack or movement.

Figure 12

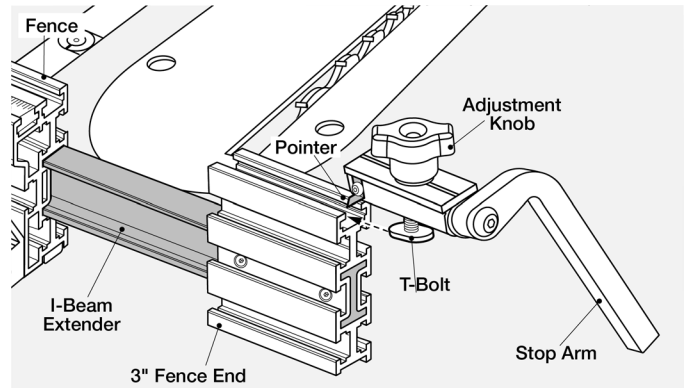

2. See Figure 13. This Fence Flip Stop is extremely versatile. The Stop Arm can be used with or without a sacrificial board. If using a sacrificial board, the angle of the specially designed arm accommodates for the extra 3/4" width and flips down. No conversion or adjustment is required.

Figure 13

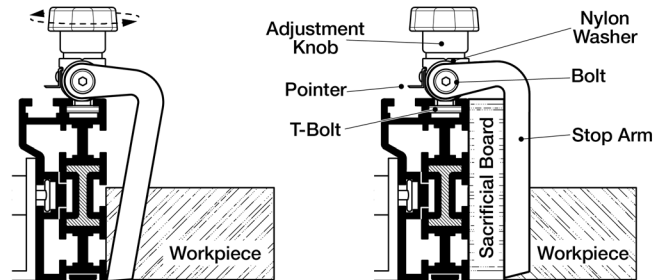

3. See Figure 14. To reposition the flip arm, use a 5 mm hex wrench (not included) to remove the bolt and move the flip arm assembly to the required side of the body. Make sure nylon washer is between the flip arm and body and replace bolt.

Figure 14

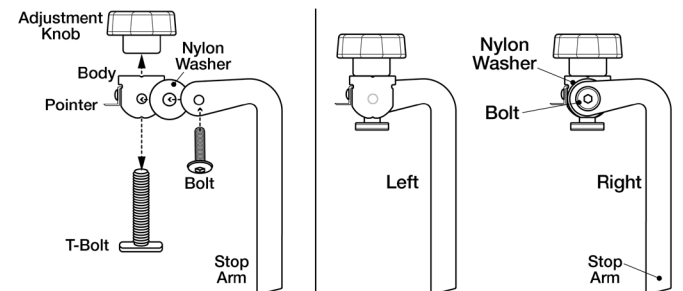

The Fence Flip Stop arm can be positioned to Left or Right of the body.
Remove Adjustment Knob and T-Bolt.
Remove Bolt, Arm and Nylon Washer of Flip Stop.
Reposition and assemble on opposite side of body.

FEATURES

The Fence is equipped with a high quality 12" Movable Scale. Calibrate the scale by using the pointer on the flip stop to provide accurate measurements. Use the Pointer to conveniently set the workpiece length.

Figure 15

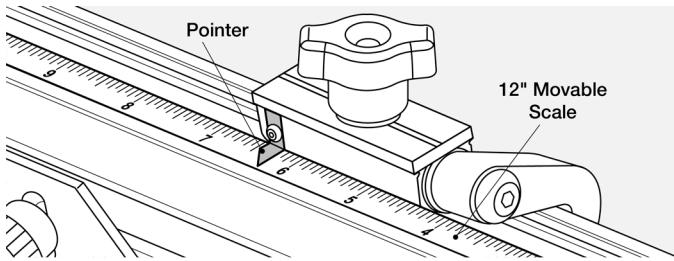

Calibrating the Scale:

1. Set the Fence a safe distance from the blade.
2. Place the right side of the flip stop to left side set tooth.
3. Align the 0 mark of the scale to the pointer.

Figure 16

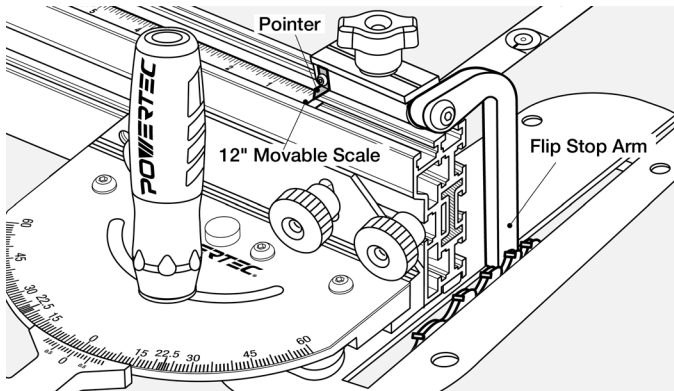

The Precision Miter Gauge Fence System is now ready to use.

NOTE: This Miter Gauge is designed to work with the included Fence. It can also be used as a conventional miter gauge.

TO USE

See Figure 17. Loosen the Handle. To unlock the Adjustment Plunger pull and twist left (counter clockwise). Release. Plunger is now in neutral position. The Miter Gauge will now move freely side-to-side.

Figure 17

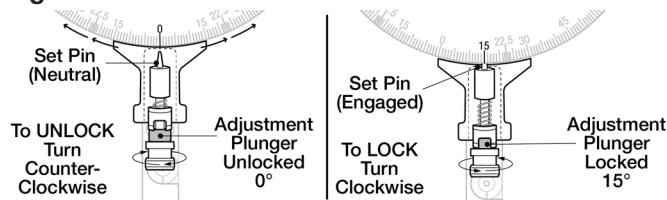

CAUTION

Always keep Adjustment Plunger in UNLOCKED position when moving set pin to any location. Failure to do so may result in damage to the Miter Gauge.

If desired angle is a positive stop, pull Adjustment Plunger and twist right (clockwise). Allow set pin to drop into notch of the desired positive stop. Release the spring loaded plunger to secure into place. Tighten the handle.

If the desired angle is not a positive stop, maneuver Miter Gauge to desired angle and tighten the handle.

For Example:

The protractor scale on the Miter Gauge head acts like a Vernier scale and precise angles can be set.

1. Loosen the handle and unlock the adjustment plunger.
2. Figure 18 shows the gauge set to 25.3 degrees. Zero is past the 25 degree mark and the upper and lower scales line up 3 marks past zero on the lower scale.
3. In Figure 19, zero is past the 18 degree mark and the upper and lower scales line up 7 marks past zero on the lower scale, for a measurement of 18.7 degrees.
4. When the angle is set, tighten the handle.

Figure 18

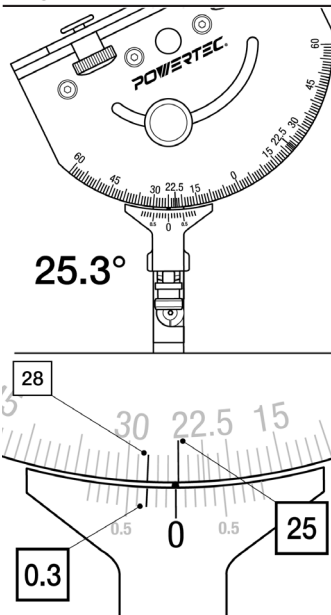
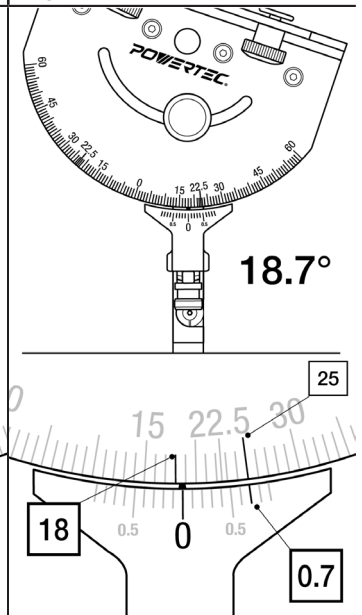

Figure 19



WARNING

When servicing, use only identical replacement parts. Use of any other parts may create a hazard or cause product damage. To ensure safety and reliability, all repairs should be performed by a qualified service technician.

WARNING

Keep the Precision Miter Gauge Fence System dry, clean, and free from oil and grease. Always use a clean cloth when cleaning. Never use brake fluids, gasoline, petroleum-based products or any strong solvent to clean the Precision Miter Gauge Fence System. Chemicals can damage, weaken or destroy plastic which may result in serious personal injury.

Visit us on the web at www.powertecproducts.com



Put these instructions and the original sales invoice in a safe, dry place for future reference.

Southern Technologies, LLC • Chicago, IL 60606