

INSTRUCTION SHEET

POWERTEC®

Complete Doweling Jig Kit

MODEL NO. 71714



NOTE: These doweling jigs can be used with any size stock, but each individual jig is designed for a specific size stock.

71715: 1/4" doweling jig to center dowels in 1/2" stock

71716: 3/8" doweling jig to center dowels in 3/4" stock

71717: 1/2" doweling jig to center dowels in 1" stock.

NOTE: Failure to follow these instructions could result in misalignment

PACKAGING CONTENTS

- 1 - 71715: 1/4" dowel drilling jig with alignment mark, included depth scale, cobalt M-35 drill bit and split ring stop collar
- 1 - 71716: 3/8" dowel drilling jig with alignment mark, included depth scale, cobalt M-35 drill bit and split ring stop collar
- 1 - 71717: 1/2" dowel drilling jig with alignment mark, included depth scale, cobalt M-35 drill bit and split ring stop collar

WARNING

- To avoid serious injury, keep hands and fingers away from the spinning bit during drilling operations. Always be aware of the bit when drilling.

- Before drilling, make sure the dowel drilling jig is clamped securely to the workpiece and the workpiece is secured in a vise or clamp. Failure to do so could result in unexpected shifting of the project during drilling, which could cause damage to the project.

TO USE

- Align the workpieces exactly as they will be joined. Make sure all faces and edges are flush.
- Decide how many dowels will be needed to join the workpieces.
NOTE: The dowel drilling jig has reference lines on the jig body for centering two dowel holes or aligning single dowel holes. In most cases, two dowels are centered on the narrowest workpiece.
- Use a combination or try square to draw a straight line where the two workpieces will be joined. This will be the line used to align the dowel drilling jig to the workpieces. See Figure 1.

NOTE: A straight edge can be used if a square is not available.

Figure 1

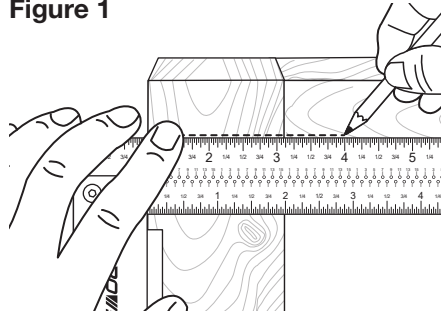

- Determine the depth of the hole to be drilled based on the length of the dowel being used.
- Slide the stop collar onto the bit (do not tighten) and place the stop collar onto the jig body. Adjust the tip of the bit to align with the desired drilling depth on the depth scale and tighten the set screw. See Figure 2.
- Clamp the jig to the workpiece. **MAKE SURE** the line and pencil mark are still aligned.
- Drill the hole. **MAKE SURE** the set up and drill are as straight as possible. See Figure 4. **NOTE:** Make several plunges, retracting the drill bit to clear away chips in between plunges. **DO NOT** force the bit.

Figure 2

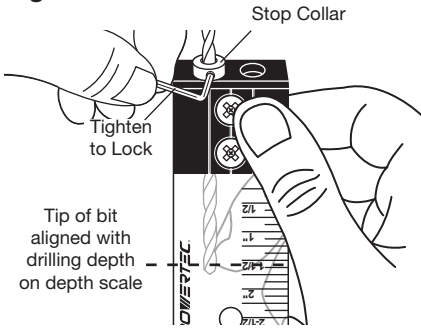

NOTE: When drilling two holes, place the body flat on the workpiece, align the central line on the body with the pencil mark. See Figure 3.

NOTE: When drilling single holes, place the body flat on the workpiece, align one of the two outside lines with the center of the hole being drilled.

Figure 3

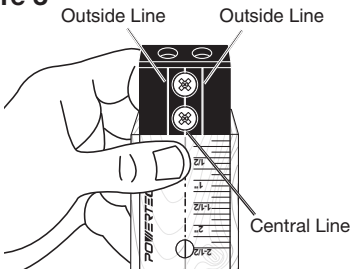
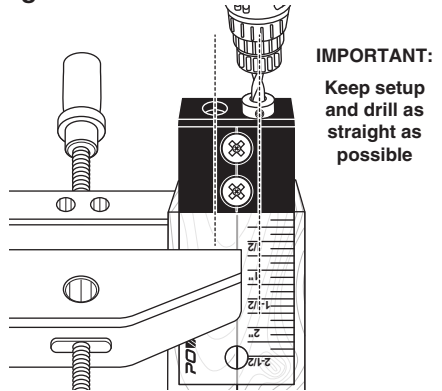

Figure 4



- Repeat the steps to drill holes in the other workpieces.
- After all holes are drilled, glue and assemble the pieces as per the dowel instructions.

Visit us on the web at powertecproducts.com



Put these instructions and the original sales invoice in a safe, dry place for future reference.

Southern Technologies, LLC
Waukegan, IL 60087