

Surface Mount Corner Bracket



PACKAGING CONTENTS

ITEM	DESCRIPTION	QUANTITY
A	Bracket, 2-5/8" tall and 3-1/4" wide	12

HARDWARE NEEDED (SOLD SEPARATELY)

ITEM	DESCRIPTION	QUANTITY
B	Hanger bolts 5/16"-18 x 3"	24
C	5/16"-18 Nuts	24
D	Pan head screws #8 x 5/8"	96

NOTE: Figure 1 shows the hardware (sold separately) needed for the assembly of one bracket (supplied).

Figure 1

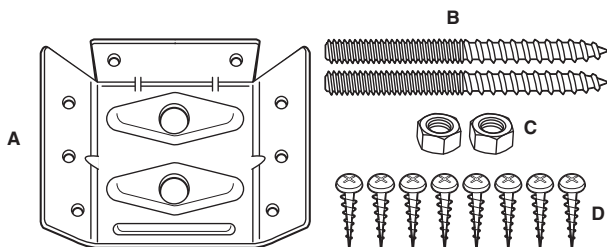

TOOLS NEEDED

- Phillips screw driver
- 1/2" wrench or socket
- Drill bits for Pilot holes
 - #8 wood screw - 5/64" for soft wood and 3/32" for hard wood
 - 5/16"-18 hanger bolt - 9/32" for soft wood, 19/64" for hard wood
- Hand planer - to cut the chamfers on the corner of the legs

MOUNTING INSTRUCTIONS

1. Cut a stopped 1/2" chamfer on the top inside corners of each table leg.
2. Position a table leg and the adjoining apron pieces upside down on a flat surface. Make sure the apron pieces are positioned with the desired setback and are square to the leg.
3. Place a corner bracket so the large mounting holes are centered on the chamfer of the table leg and the flat areas are flush with the apron pieces.

Figure 2

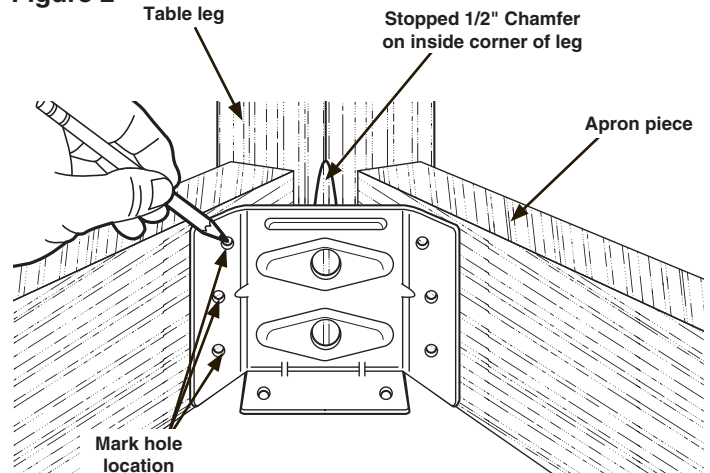

4. Repeat Steps 2 and 3 for other table legs.
5. Mark mounting hole locations for #8 x 5/8" pan head screws and drill the pilot holes. **NOTE:** Pilot holes should be 5/64" for softwood or 3/32" for hardwood.
6. Position the table legs and mark the pilot hole locations for the hanger bolts. **NOTE:** The distance from the top of the bracket (end with flange) to the centerline of the first hole is 3/4" and 1-7/8" to the second.
7. Secure the corner brackets to the apron pieces with the #8 x 5/8" pan head screws.
8. Drill the pilot holes into the legs.
9. Use two 5/16"-18 nuts to drive the hanger bolts in place. After the hanger bolts are set, remove the nuts. Place the table leg with hanger bolts in place and secure each hanger bolt with a single 5/16"-18 nut.

Figure 3

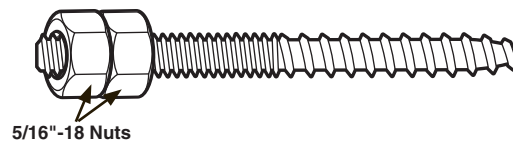
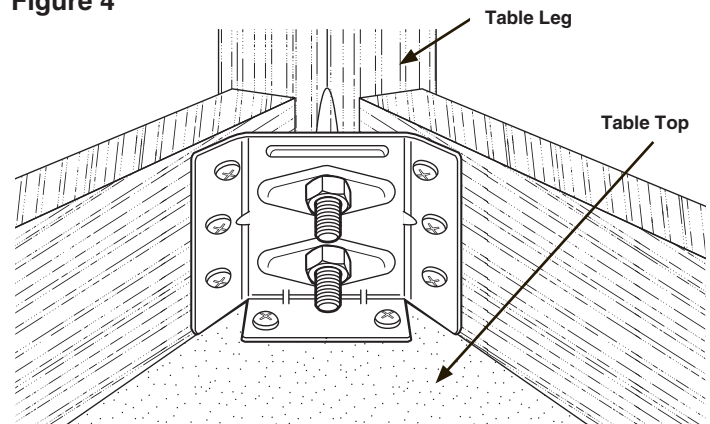

Figure 4



10. When all four brackets are assembled and the apron is complete use the two holes in the top of the bracket to mount the table top to the apron.
11. Make sure all hardware is tight.

Visit us on the web at powertecproducts.com



Put these instructions and the original sales invoice in a safe, dry place for future reference.

Southern Technologies, LLC
Waukegan, IL 60087