

POWERTEC®

Router Table Top



⚠️ WARNING

For your own safety, read all of the rules and precautions before operating tool.

⚠️ WARNING

Always follow proper operating procedures as defined in this manual even if you are familiar with use of Router Table Top or any tool used with Router Table Top. Remember that being careless for even a fraction of a second can result in severe personal injury.

Before using another tool with this product, always read, understand and follow the instructions and safety warnings in the owner's manual for that tool. If you do not have the owner's manual, obtain one from the tool's manufacturer before using it with this product.

You must be familiar with the use of any tool or accessory used with Router Table Top. The supplier cannot be held responsible for any accident, injury or damage incurred while using Router Table Top with any tool.

It is the responsibility of the purchaser of this product to ensure that any person using this product reads and complies with all instructions and safety precautions outlined in this manual and the operating manual of the tool being used prior to use.

⚠️ WARNING

Some dust created by operation of power tool contains chemicals known to the State of California to cause cancer, birth defects or other reproductive harm. To reduce your exposure to these chemicals, work in a well ventilated area and work with approved safety equipment. Always wear OSHA/NIOSH approved, properly fitting face mask or respirator when using such tools.

⚠️ CAUTION

Do not modify or use Router Table Top for any application other than that for which it was designed.

FOLLOW ALL STANDARD SHOP SAFETY PRECAUTIONS, INCLUDING:

- Keep children and visitors at a safe distance from work area.
- Keep work area clean. Cluttered work areas invite accidents. Work area should be properly lit.
- Do not use power tools in dangerous environments. Do not use power tools in damp or wet locations. Do not expose power tools to rain.
- TURN OFF AND UNPLUG all power tools BEFORE making any adjustments or changing accessories.
- Be alert and think clearly. Never operate power tools when tired, intoxicated or when taking medications that cause drowsiness.
- Wear proper apparel. Do not wear loose clothing, gloves, neckties, rings, bracelets or other jewelry which may get caught in moving parts of the tool.
- Wear protective hair covering to contain long hair.
- Wear safety shoes with non-slip soles.
- Wear safety glasses complying with United States ANSI Z87.1. Everyday glasses have only impact resistant lenses. They are NOT safety glasses.
- Wear face mask or dust mask if operation is dusty.
- A guard or any other part that is damaged should be properly repaired or replaced. Do not perform makeshift repairs.
- Use safety equipment such as featherboards, push sticks and push blocks, etc., when appropriate.
- Maintain proper footing at all times and do not overreach.
- Do not force woodworking tools.

⚠️ CAUTION

Think safety! Safety is a combination of operator common sense and alertness at all times when tool is being used.

⚠️ WARNING

Do not use the Router Table Top until it is completely assembled and you have read and understood this entire operating manual and the operating manual of the tool being used with Router Table Top.

SAVE ALL WARNINGS AND INSTRUCTIONS FOR FUTURE REFERENCE

UNPACKING

Check for shipping damage. Check immediately whether all parts and accessories are included.

ITEM	DESCRIPTION	QTY
AA	Table Top (24" wide x 32" long x 1" thick)	1
BB	Hexagon set screw 1/2"-20" (3/8"-24 internal thread)	4
CC	Hex nut 1/2"-20	4
DD	Adjustment Screw 3/8"-24 (1/4"-20 internal thread)	4
EE	Hex Nut 3/8"-24	4
FF	Stri-head Locking Screw (1/4"-20)	4
GG	Main Resin Insert	1
HH	Reducing Rings (includes solid insert, 1" & 2-5/8" openings)	3
II	Screw M3P 0.5x8mm	3
JJ	M5 Starting pin with M6 Insert	1
KK	Struts	2
LL	Screw 3/16" x 5/8" L	8
MM	3 mm Screwdriver	1
NN	M6 Hex Wrench	1

Figure 1

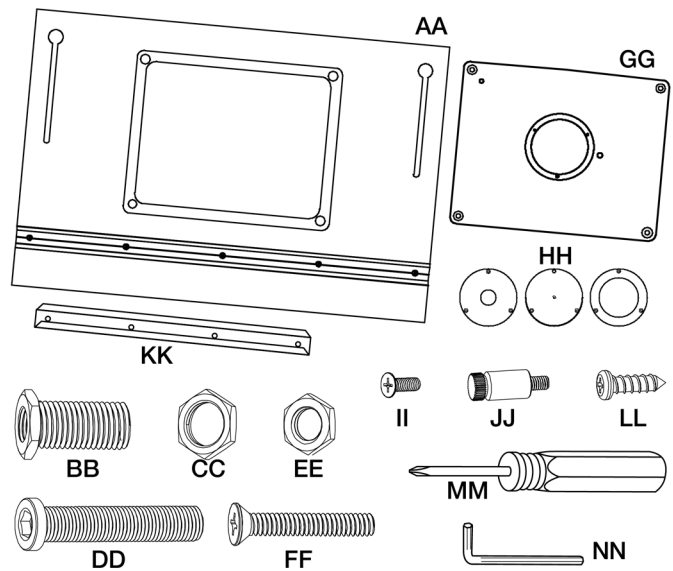
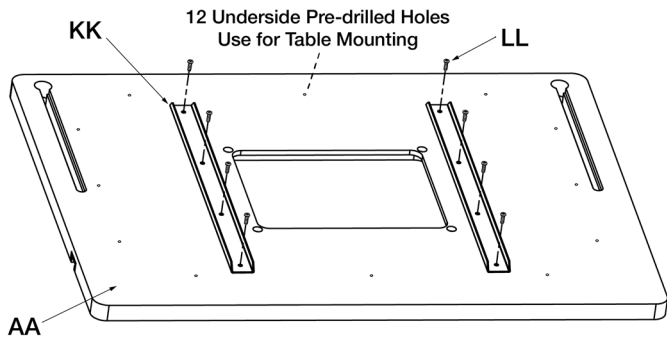

TABLE TOP ASSEMBLY

- See Figure 2. Turn Table Top (AA) over with back facing up. Place Struts (KK) in position over predrilled holes. Using Screws (LL) secure Struts to back of Table Top.

Figure 2



NOTE: Observe the 12 pre-drilled holes on table underside. Use these for mounting the router table onto POWERTEC UT1006 Router Table Stand. Due to the T-Track on table top, ALWAYS be aware of location of T-Track before drilling. Use appropriate length hardware. Do not drill through.

- See Figure 3. Hand tighten Adjustment Screw (DD) into the Hexagon Set Screw (BB). Place the assembly into the holes in the insert opening and tighten Hex Nut (CC) against the bottom of the table. Place Hex Nut (EE) onto Adjustment Screw (DD). DO NOT tighten at this time. Repeat on all four holes.

Figure 3

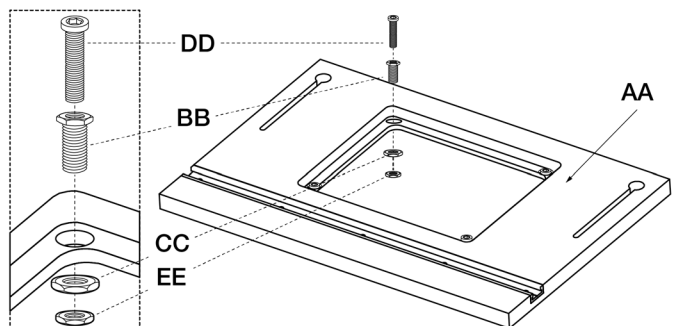

ROUTER DRILL PATTERNS

- See Figure 4. Resin Insert (GG) has lettered center points molded into the bottom face using drill patterns for the most common routers. Locate your router on the following chart and use the lettered pattern indicated. Drill a hole matching the size of the mounting screws supplied with your router. Once the holes are drilled, flip the insert plate over and counter bore, or counter sink the drilled holes to seat the mounting screws below the surface of the mounting plate.

Figure 4

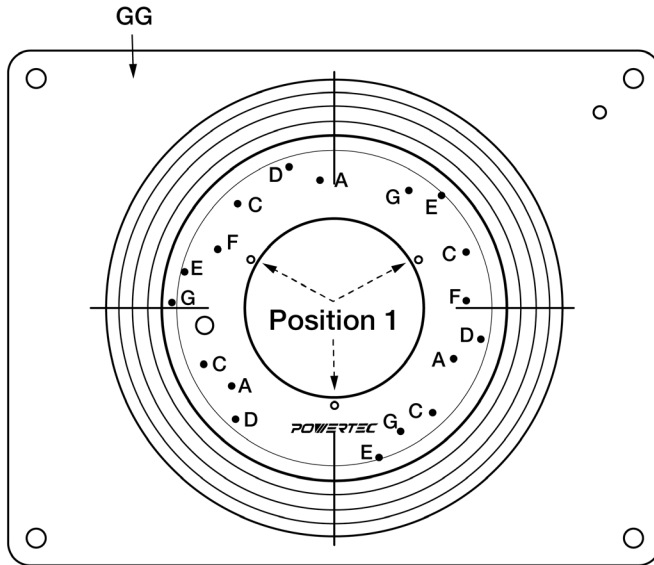

NOTE: Drill holes and counterbores or countersinks to accommodate the mounting screws supplied with the router. For routers equipped with a built-in lift system, use the router sub-base as a guide for the location and size of the access hole and as a drilling guide.

PORTER CABLE*	A	690 Series	A	8529
	A	7529		
DEWALT*	F	DW621	A	DW616 Series
	F	DW625	A	DW618 Series
Craftsman*	C	315 275 000	E	315 175 060
	D	315 175 040	D	315 175 070
	D	315 175 050		
Bosch*	A	1617 (fixed base)	A	1618
	G	1617 (plunge base)	A	MR23 Series
Makita*	A	RF1101		
Ryobi*	C	R1631K		
Milwaukee*	A	5615	A	5616
	A	5619		
Fein*	F	FT 1800		
Elu*	F	177		
Hitachi*	A	M-12VC		

* PORTER-CABLE, DEWALT, Craftsman and Elu are trademarks of The Stanley Black & Decker Corporation—Bosch is a trademark of the Robert Bosch Tool Corporation—Makita is a trademark of Makita Corporation—Ryobi is a trademark of Ryobi Limited and is used by Techtronic Industries Company LTD—Milwaukee is a trademark of Techtronic Industries Company LTD—Fein is manufactured by C. & E. Fein GmbH—Hitachi is a trademark of Hitachi, Ltd.

FOR ROUTERS NOT COVERED BY CHART:

- See Figure 5-6. With target pattern facing up—place Resin Insert (GG) onto workbench.

Figure 5

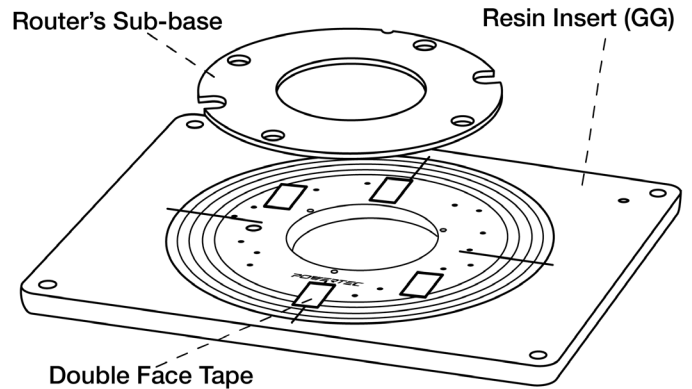

- Remove sub-base from router. Check router base holes to ensure alignment with any of the center point patterns. If so, use that pattern.
- If no existing patterns match up, select a drill bit that fits the mounting holes of your subbase. If router is equipped with a built-in lift system, select a bit that fits the lift-access hole.
- Apply several small pieces of double-faced tape to the insert plate. Now, center the sub-base on the plate, using the concentric arcs of the target pattern as guides.
- Be aware of the router control position. Ensure drill holes align with threaded holes of the start pin or the predrilled center points. Press the subbase firmly onto the insert plate.

NOTE: Before drilling, securely clamp insert plate to drill-press table or bench to prevent movement while drilling. Whether using a drill press or hand drill, place a wood scrap under insert plate to reduce chipping when drill bit passes through the plate. Performing this operation on a drill press ensures holes are perpendicular to the plate.

- See Figure 6. Use the holes in the sub-base as a pattern to mark holes needed. Drill holes into the insert plate using a drill press or hand drill.

Figure 6

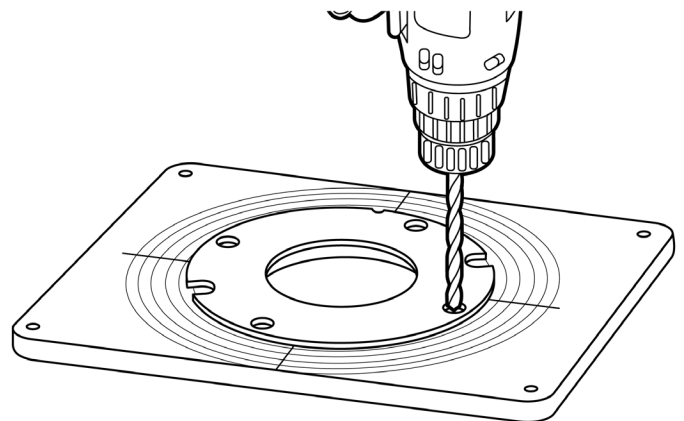

- With holes drilled, remove sub-base from insert plate. Flip plate over and countersink mounting holes assuring machine screw heads sit below plate surface when tightened.

IMPORTANT: Store router sub-base in a convenient place. It will be needed when removing router from router table and during handling.

3. See Figure 7. Using the screws for attaching the sub-base to the router, attach router base to Resin Insert (GG).

NOTE: Depending on the thickness of your router sub-base, it may be necessary to purchase longer screws. Make certain the screws are long enough to fully thread into the router base. If you are mounting a fixed-base router, install the motor unit in the router base.

Figure 7

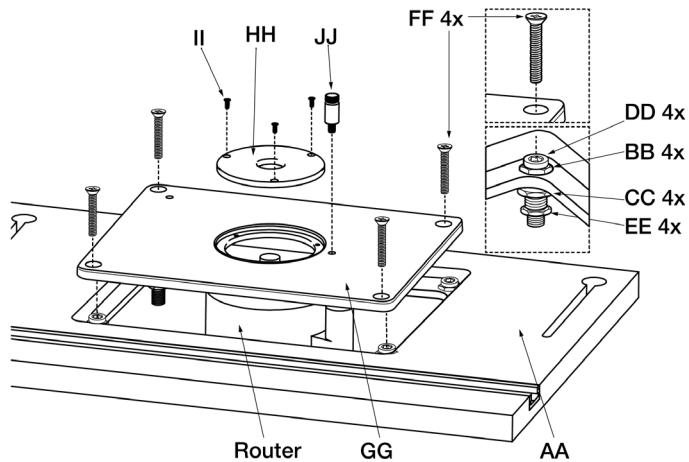

- Place Resin Insert (GG), with the router attached, into Router Table Top (AA) opening, resting it on the Adjustment Screws (DD). Using the M6 Hex Wrench (NN) provided, adjust the adjustment screws through the holes in the insert plate. Use a straight edge to verify the insert plate is flush with the tabletop. Once flush, tighten Hex Nuts (EE). If not flush, fine-tune the adjustment screws until the insert plate is flush with the tabletop.
- Thread the four Flat-head Screws (FF) through the countersunk holes in the insert plate and into the center hole on each adjustment screws and tighten, locking the insert plate in place. Some adjustment of the lock down screws and adjustment screws may be necessary to fine-tune the alignment.
- Choose the reducing ring appropriate for the job and attach it to the insert plate using the three Set Screws (I I). When needed, thread the Starting Pin (JJ) into the threaded hole in the insert plate and tighten.

REDUCING RINGS

See Figure 8. There are three reducing rings for flexibility in matching the size of the insert opening to the diameter of the router bit in use; a solid insert, to be bored for any custom size, an insert with a 1" opening, and an insert with a 2-5/8" opening. To install a reducing ring, simply drop it into the insert-plate opening and attach using the three M3 set screws (II) with the 3mm Screwdriver (MM) provided.

Figure 8

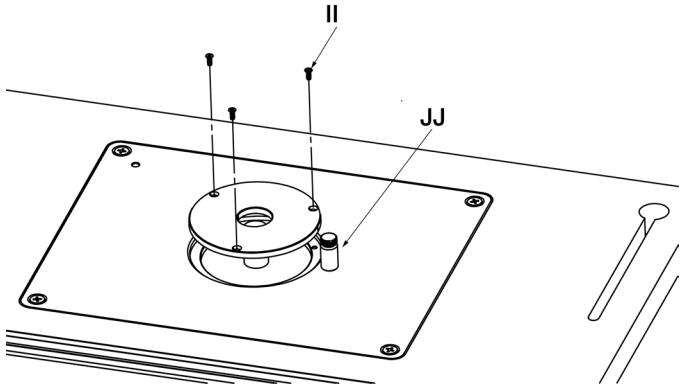

STARTING PIN

To use the Starting Pin (JJ), begin with your workpiece touching the pin, but not in contact with the router bit. Slowly pivot the workpiece into the bit until the workpiece makes contact with the bit guide bearing. Always feed the workpiece so the router bit rotates against (not with) the feed direction. With the workpiece in solid contact with the guide bearing, ease the workpiece off of the starting pin and feed the workpiece against the guide bearing.

WARNING

Use the starting pin when routing along curved edges and only with router bits that have a guide bearing. When routing along straight edges, always use the fence.

GENERAL MAINTENANCE

WARNING

When servicing, use only identical replacement parts. Use of any other parts may create a hazard or cause product damage. To ensure safety and reliability, all repairs should be performed by a qualified service technician.

WARNING

Keep the Router Table Top dry, clean, and free from oil and grease. Always use a clean cloth when cleaning. Never use brake fluids, gasoline, petroleum based products or any strong solvent to clean the Router Table Top. Chemicals can damage, weaken or destroy plastic which may result in serious personal injury.

Visit us on the web at www.powertecproducts.com



Put these instructions and the original sales invoice in a safe, dry place for future reference.

Southern Technologies, LLC
Chicago, IL 60606