

POWERTEC®

Twin Pocket Hole Jig Set



SAFETY RULES

WARNING

For your own safety, read all of the rules and precautions before operating tool.

WARNING

Always follow proper operating procedures as defined in this manual even if you are familiar with use of this pocket hole jig or any tool used with this pocket hole jig. Remember that being careless for even a fraction of a second can result in severe personal injury.

Before using another tool with this product, always read, understand and follow the instructions and safety warnings in the owner's manual for that tool. If you do not have the owner's manual, obtain one from the tool's manufacturer before using it with this product.

You must be familiar with the use of any tool or accessory used with this pocket hole jig. The supplier cannot be held responsible for any accident, injury or damage incurred while using this pocket hole jig with any tool.

It is the responsibility of the purchaser of this product to ensure that any person using this product reads and complies with all instructions and safety precautions outlined in this manual and the operating manual of the tool being used prior to use.

WARNING

Some dust created by operation of power tool contains chemicals known to the State of California to cause cancer, birth defects or other reproductive harm. To reduce your exposure to these chemicals, work in a well ventilated area and work with approved safety equipment. Always wear OSHA/NIOSH approved, properly fitting face mask or respirator when using such tools.

CAUTION

Do not modify or use this pocket hole jig for any application other than that for which it was designed.

FOLLOW ALL STANDARD SHOP SAFETY PRECAUTIONS, INCLUDING:

- Keep children and visitors at a safe distance from work area.

- Keep work area clean. Cluttered work areas invite accidents. Work area should be properly lit.
- Do not use power tools in dangerous environments. Do not use power tools in damp or wet locations. Do not expose power tools to rain.
- TURN OFF AND UNPLUG all power tools BEFORE making any adjustments or changing accessories.
- Be alert and think clearly. Never operate power tools when tired, intoxicated or when taking medications that cause drowsiness.
- Wear proper apparel. Do not wear loose clothing, gloves, neckties, rings, bracelets or other jewelry which may get caught in moving parts of the tool.
- Wear protective hair covering to contain long hair.
- Wear safety shoes with non-slip soles.
- Wear safety glasses complying with United States ANSI Z87.1. Everyday glasses have only impact resistant lenses. They are NOT safety glasses.
- Wear face mask or dust mask if operation is dusty.
- A guard or any other part that is damaged should be properly repaired or replaced. Do not perform makeshift repairs.
- Use safety equipment such as featherboards, push sticks and push blocks, etc., when appropriate.
- Maintain proper footing at all times and do not overreach.
- Do not force woodworking tools.

CAUTION

Think safety! Safety is a combination of operator common sense and alertness at all times when tool is being used.

CAUTION

Do not use the pocket hole jig until it is completely assembled and you have read and understood this entire operating manual and the operating manual of the tool being used with this pocket hole jig.

SAVE ALL WARNINGS AND INSTRUCTIONS FOR FUTURE REFERENCE

SPECIFIC SAFETY WARNINGS

- Before any using the pocket hole jig, be sure everyone using the product reads and understands all safety instructions and other information contained in the drills manufacturer's manual.
- The drill bit is sharp. Handle with care.
- Avoid awkward hand positions where a sudden slip could cause contact with the rotating bit.
- Properly secure your workpiece before drilling. Do not attempt to hold the pocket-hole jig in place with your hand while drilling. Secure it to the workpiece with a clamp.
- Do not allow familiarity gained from frequent use of tools replace safe work practices. A moment of carelessness is sufficient to cause severe injury.

UNPACKING

Refer to Figure 1

Check for shipping damage. Check immediately whether all parts and accessories are included.

ITEM	DESCRIPTION	QTY
A	Pocket hole jig	1
B	Dust collector adapter	1
C	3/8" drill bit	1
D	R2 driver bit	1
E	Hex key	1
F	3/8" stop collar	1

Figure 1

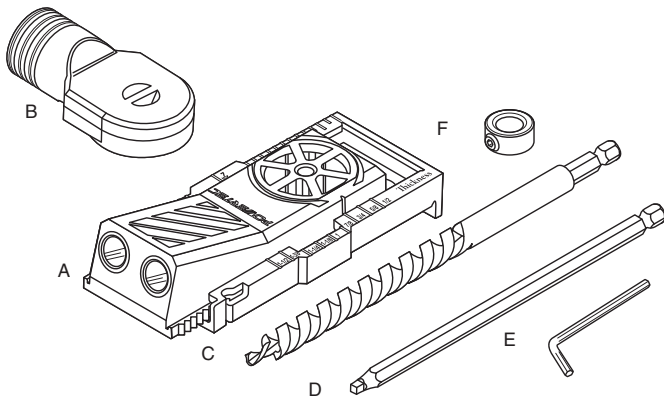

WARNING

The pocket hole jig is completely assembled. Before using make sure you have read and understood this entire operating manual and the operating manual of the drill being used.

DUST COLLECTOR ADAPTER

The pocket hole jig is equipped with a dust collector adapter, it can be used with or without the adapter.

1. Snap the dust collector adapter onto the top of the pocket hole jig.
2. Connect it to a dust extractor or dust collector.
3. Adjust the dust collector adapter to the needed position, it can be rotated over 180°.

Figure 2

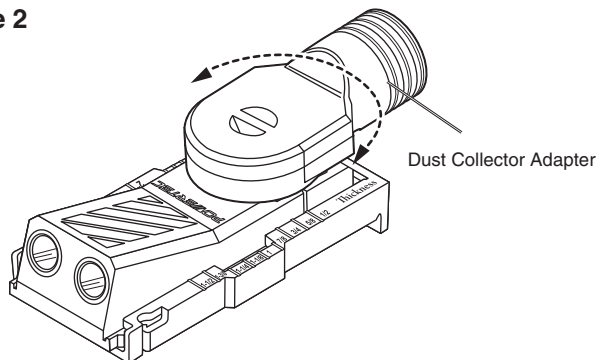

SET UP - TO DRILL POCKET HOLES

1. Measure your material thickness.
2. On the side of the pocket jig is a material thickness alignment mark and measurements. Slide the body of the jig in or out to align the alignment mark with the measurement of the material thickness. The mark is aligned to 3/4" material thickness in Figure 3.

Figure 3

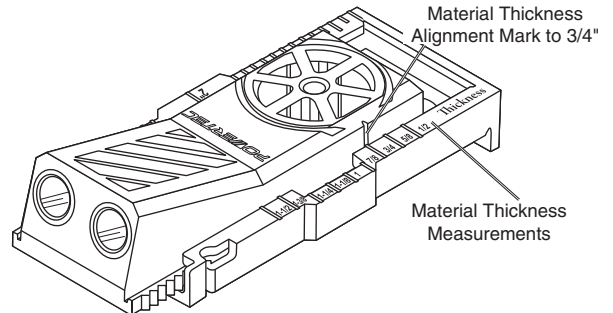

3. Turn the pocket hole jig over to set the drill depth position.
 - a. Slide the 3/8" stop collar on to the 3/8" drill bit. Do not tighten.
 - b. Slide the drill bit into the pocket hole jig and align the second step of the drill bit with the scale mark.
 - The thickness of the material is less than 7/8", aligned with the first mark
 - Material thickness is 1" – 1-1/8", align with the second mark
 - Material thickness is greater than 1-1/4", align with the third mark
 - c. Slide the 3/8" stop collar to the edge of pocket hole jig and tighten the screws on the stop collar with the hex key (provided).

Figure 4

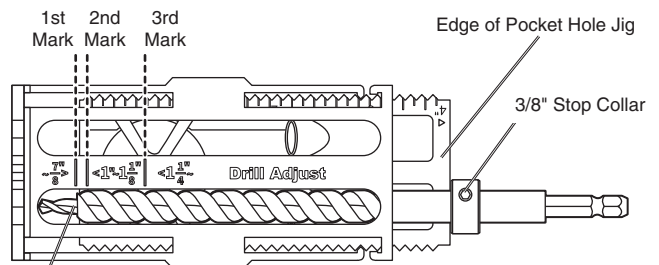

3/8" Drill Bit shown aligned to the first mark (material thickness is less than 7/8")

DRILLING POCKET HOLES

1. Position the pocket hole jig in place and clamp it to the workpiece.
 - Place pocket holes 5/8" to 1-1/2" from the edge and every 6" to 8" apart.
 - If not using the dust collector adapter, DO NOT block the chip ejection holes.
 - There are three alignment marks on the front of the jig. The middle line aligns to the center between the two holes to be drilled. The two side lines align to the center of the two holes to be drilled.

Figure 5

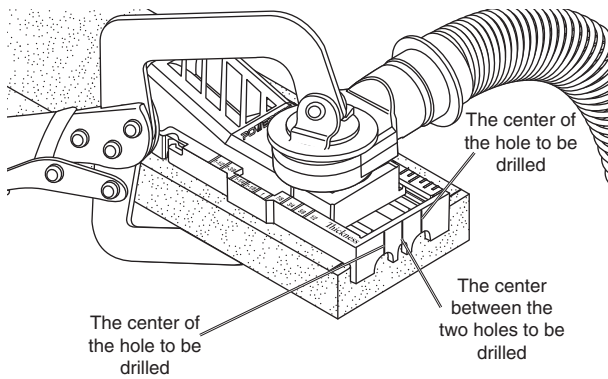

NOTE: When drilling two holes, align the central line on the jig with the mark.

NOTE: When drilling single holes, align one of the two outside lines with the center of the hole being drilled.

2. Start to drill the hole, drill at a slow speed until the stop collar touches the edge of the jig.

Figure 6

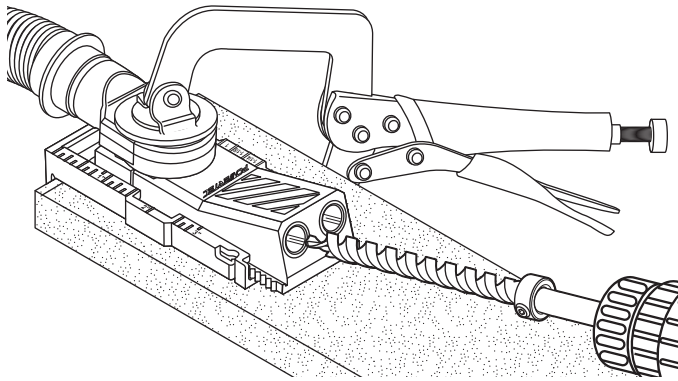

Drilling Holes into Assembled Material

The POWERTEC Pocket Hole Jig can also be used to repair or strengthen previously assembled case goods or drawers.

1. Reference the **Drilling After Assembly** chart for the appropriate drill length for the material thickness
2. Measure from the bottom of the stop collar to the first step of the drill bit and tighten the stop collar.

Figure 7

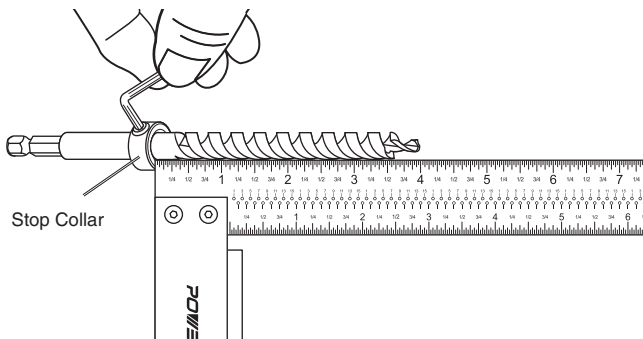

3. Remove the pocket hole jig body from the pocket hole jig slide bracket.

Figure 8

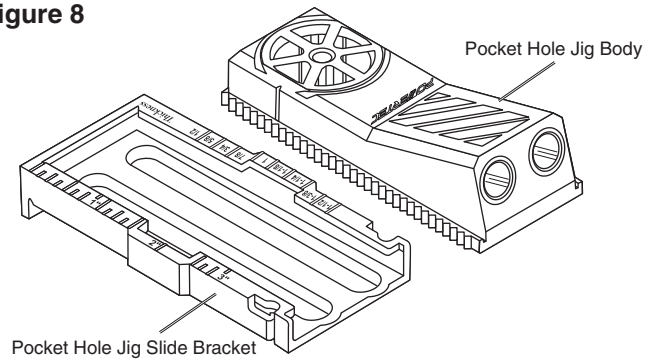

4. Scribe a line on the assembled material. Reference the **Drilling After Assembly** chart for distant from the edge measurement
5. Align the edge of the pocket hole jig to the scribed line and clamp firmly in place with the appropriate clamp for the application.

Drilling After Assembly

Material Thickness	Distance from Edge	Drill Length	Screw Length
1/2"	NOT RECOMMENDED		
5/8"	Snap to edge	3-1/2"	1"
3/4"	1/8"	3-1/2"	1-1/4"
7/8"	3/8"	3-3/4"	1-1/2"
1"	5/8"	3-3/4"	1-1/2"
1-1/8"	7/8"	4"	1-1/2"
1-1/4"	1-1/16"	4"	2"
1-3/8"	1-5/16"	4"	2"
1-1/2"	1-9/16"	4"	2-1/2"

Figure 9

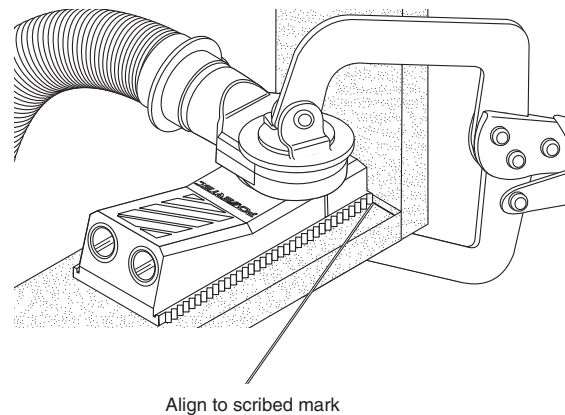

6. Start to drill the hole, drill at a slow speed until the stop collar touches the edge of the jig.

DRIVE POCKET HOLE SCREWS

1. Reference the **Recommended Screw Length** chart for the correct screw length for the material thickness used.

Recommended Screw Length

Material Thickness	Screw Length
1/2"	1" *
5/8"	1"
3/4"	1-1/4"
7/8"	1-1/2"
1"	1-1/2"
1-1/8"	1-1/2"
1-1/4"	2"
1-3/8"	2"
1-1/2"	2-1/2"

* Panhead pocket screws are recommended.

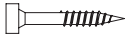

NOTE: Screw length is measured from the bottom of the head to the tip of the screw.

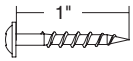

2. Use the R2 driver bit (supplied) to drive the wood screws into the material.

Figure 10

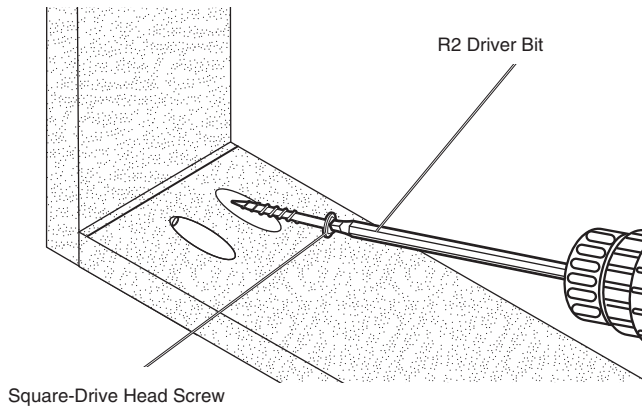

GENERAL MAINTENANCE

WARNING

When servicing, use only identical replacement parts. Use of any other parts may create a hazard or cause product damage. To ensure safety and reliability, all repairs should be performed by a qualified service technician.

WARNING

Keep the pocket hole jig dry, clean, and free from oil and grease. Always use a clean cloth when cleaning. Never use brake fluids, gasoline, petroleum based products or any strong solvent to clean the pocket hole jig. Chemicals can damage, weaken or destroy plastic which may result in serious personal injury.

POWERTEC®

Visit us on the web at www.powertecproducts.com



Put these instructions and the original sales invoice in a safe, dry place for future reference.

Southern Technologies, LLC
Chicago, IL 60606