

INSTRUCTION SHEET

POWERTEC®

71094 - Steel Table Top

Fasteners w/ Screws, 10 Sets

71580 - Steel Table Top

Fasteners w/ Screws, 24 Sets



PACKAGING CONTENTS

		71094	71580
ITEM	DESCRIPTION	QUANTITY	QUANTITY
A	Tabletop fasteners	10	24
B	Mounting screws	10	24

NOTE: Figure 1 shows one tabletop fastener set with hardware.

Figure 1

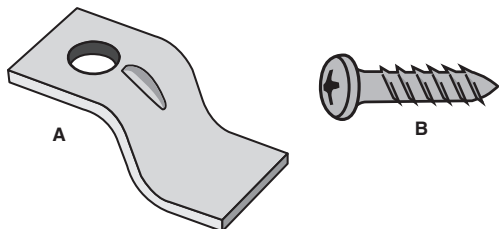

TOOLS NEEDED

Phillips screw driver

Table saw or Biscuit jointer: used to create the needed groove/kerf in the apron

MOUNTING INSTRUCTIONS

These tabletop fasteners may be used on any table with a 3/32" wide x 5/16" deep groove/kerf that is located 1/2" from the top of the apron. If needed, a biscuit jointer may be used to create the groove/kerf. Follow all instructions provided with the biscuit jointer.

1. Place the tabletop upside down onto a non-marring surface.
2. Position the table leg/apron assembly onto the tabletop. Make sure all parts are aligned and the desired overhang is obtained.

3. Determine how many tabletop fasteners are needed to secure the tabletop to the table leg/apron assembly.
 - The fasteners should be 8" to 10" apart.
 - Fastener location is determined by the type of material the tabletop is made:
 - **Solid wood:** Place the tabletop fasteners on two sides of the table leg/apron assembly, running along the grain of the tabletop. This will allow the tabletop to expand and contract without binding or cupping. **NOTE:** Solid wood expands and contracts with seasonal changes across the grain, but not along the grain.
 - **Plywood or other sheet goods:** Place the tabletop fasteners on all sides of the table leg/apron assembly **NOTE:** These materials do not expand or contract with seasonal changes.
4. Place the tabletop fasteners in the groove/kerf and position them in the desired locations. Use the hole in the fastener to mark mounting hole locations for the supplied #8 x 5/8" pan-head screws.
5. Remove the fasteners and drill the pilot holes. **NOTE:** Pilot holes should be 7/64" for softwood or 11/64" for hardwood. Be careful not to drill through the tabletop.
6. Reposition the tabletop fasteners into the groove/kerf and secure with the supplied #8 x 5/8" pan head screws.
7. Make sure all hardware is tight.

Figure 2

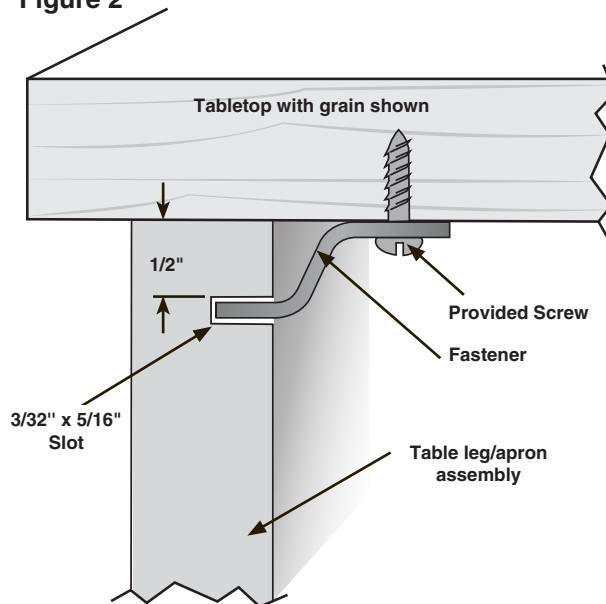

Visit us on the web at powertecproducts.com



Put these instructions and the original sales invoice in a safe, dry place for future reference.

Southern Technologies, LLC
Waukegan, IL 60087