

INSTRUCTION SHEET

POWERTEC®

Urethane Band Saw Tires, 2PK



⚠ WARNING To reduce the risk of injury, turn bandsaw off and disconnect it from power source before installing and removing accessories. An accidental start-up can cause injury.

⚠ WARNING For your own safety, read and follow all safety procedures listed in the bandsaw instruction manual.

PACKAGING CONTENTS

2 - Urethane Band Saw Tires

ASSEMBLY

To Replace the Tires without Removing the Wheels

NOTE: Soaking the tires in hot water will help make them more flexible.

1. Remove the bandsaw blade and old tires from the wheels. Clean the wheels. See the machine's instruction manual for the correct procedure.
2. Place the new tire onto the wheel and clamp the tire and wheel to the bandsaw.

Figure 1

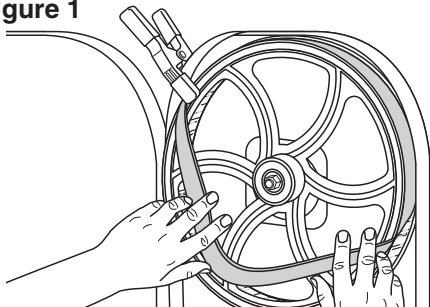

3. Work the tire around the wheel to the half way point, use another clamp to secure the tire and wheel in place.

Figure 2

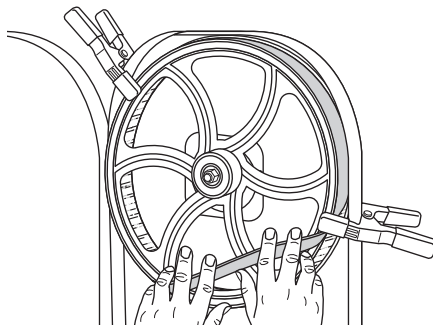

4. Continue working the tire around the wheel. If needed, a screwdriver or wooden dowel can be used to help work the tire onto the wheel.

Figure 3

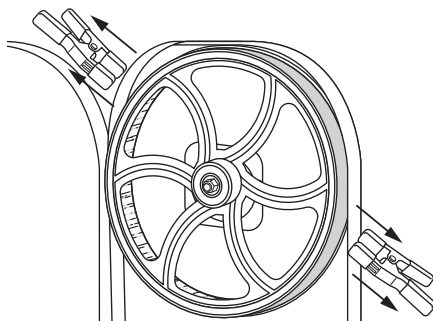

5. After the tire is on the wheel, remove the clamps.
6. Work the tire around the wheel and make sure the tire slides into the grooves and is properly seated on the wheel.
7. If the tire is too wide and will not seat firmly in the groove of the wheel, use a utility knife and trim to fit.
8. Repeat these steps on the second wheel.
9. Replace the bandsaw blade. See the machine's instruction manual for the correct procedure.

To Replace the Tires with the Wheels Removed

NOTE: Soaking the tires in hot water will help make them more flexible.

1. Remove the upper and lower wheels from the machine. See the machine's instruction manual for the correct procedure.
2. Remove the bandsaw blade and old tires from the wheels. Clean the wheels. See the machine's instruction manual for the correct procedure.
3. Place the new tire onto the wheel and secure the tire to the wheel with a clamp.

Figure 4

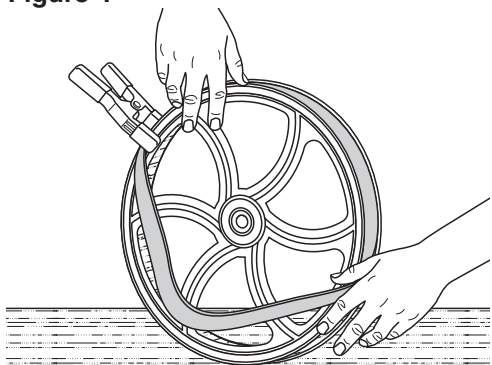

4. Work the tire around the wheel to the half way point, use another clamp to secure the tire to the wheel.

Figure 5

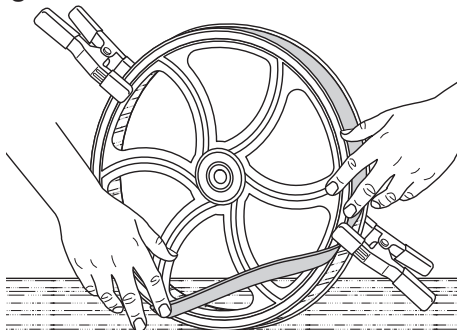

5. Rotate the wheel and continue working the tire around the wheel. If needed, a screwdriver or wooden dowel can be used to help work the tire onto the wheel.

Figure 6

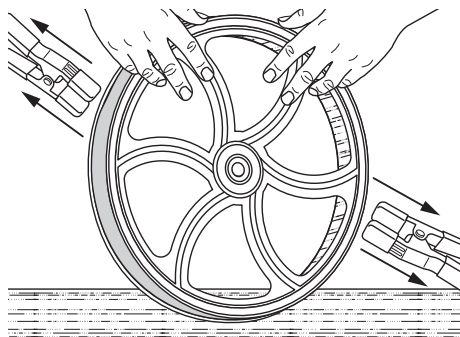

6. After the tire is on the wheel, remove the clamps.
7. Work the tire around the wheel and make sure the tire slides into the grooves and is properly seated on the wheel.
8. If the tire is too wide and will not seat firmly in the groove of the wheel, use a utility knife and trim to fit.

Figure 7

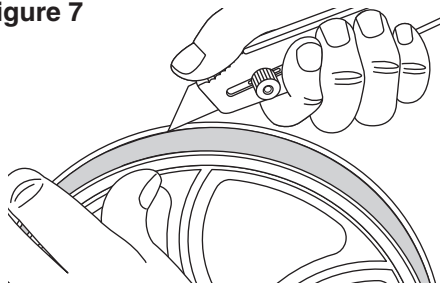

9. Repeat these steps on the second wheel.
10. Replace the wheels onto the bandsaw. See the machine's instruction manual for the correct procedure.
11. Replace the bandsaw blade. See the machine's instruction manual for the correct procedure.

Visit us on the web at powertecproducts.com



Put these instructions and the original sales invoice in a safe, dry place for future reference.

Southern Technologies, LLC
Waukegan, IL 60087