

# Owner's Manual

# **POWERTEC**<sup>®</sup>

## **24" Router Table Fence**

---

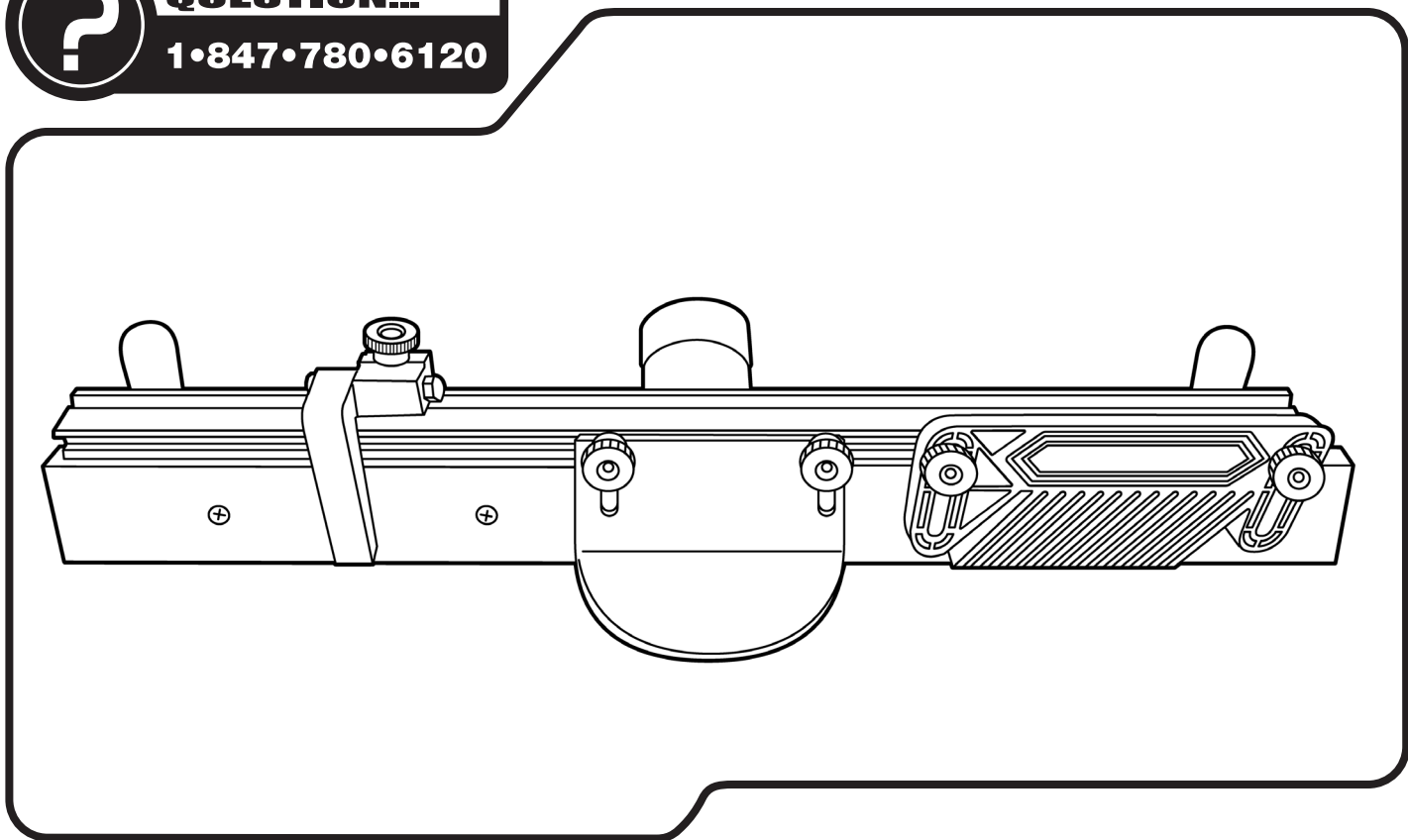

Visit us on the web at [www.powertecproducts.com](http://www.powertecproducts.com)



You will need this manual for safety instructions, operating procedures, and warranty. Put it and the original sales invoice in a safe, dry place for future reference.

# TABLE OF CONTENTS

SECTION PAGE



## SAFETY RULES

1-2

Safety Rules



## PARTS AND CONTENTS

3

Unpacking



## ASSEMBLY

4-5

Assembly  
Adjusting the Fence Faces



## OPERATION

6

Operation



## MAINTENANCE

6

General Maintenance  
Notes



## WARRANTY

9

Warranty

# PRODUCT SPECIFICATIONS

## RECOMMENDED ROUTER BIT SPEEDS

BIT DIAMETER	MAXIMUM SPEED
Up to 1" (25 mm) .....	.22,000 -24,000 rpm
1" to 2" (25 mm–51 mm) .....	18,000-22,000 rpm
2" to 2-1/2" (51 mm–64 mm) .....	12,000-16,000 rpm
2-1/2" to 3-1/2" (64 mm–89 mm) .....	8,000-12,000 rpm

**NOTE:** Always follow bit manufacturer's speed recommendations. Some bit designs require specific speeds for safety or performance.

# SAFETY RULES



1

## WARNING

For your own safety, read all of the rules and precautions before operating tool.

## WARNING

Always follow proper operating procedures as defined in this manual even if you are familiar with use of this router table fence or any tool used with this router table fence. Remember that being careless for even a fraction of a second can result in severe personal injury.

Before using another tool with this product, always read, understand and follow the instructions and safety warnings in the owner's manual for that tool. If you do not have the owner's manual, obtain one from the tool's manufacturer before using it with this product.

You must be familiar with the use of any tool or accessory used with this router table fence. The supplier cannot be held responsible for any accident, injury or damage incurred while using this router table fence with any tool.

It is the responsibility of the purchaser of this product to ensure that any person using this product reads and complies with all instructions and safety precautions outlined in this manual prior to use.

## WARNING

Some dust created by operation of power tool can expose you to chemicals known to the State of California to cause cancer, birth defects or other reproductive harm. To reduce your exposure to these chemicals, work in a well ventilated area and work with approved safety equipment. Always wear OSHA/NIOSH approved, properly fitting face mask or respirator when using such tools.

## CAUTION

Do not modify or use this router table fence for any application other than that for which it was designed.

## FOLLOW ALL STANDARD SHOP SAFETY PRECAUTIONS, INCLUDING:

- Keep children and visitors at a safe distance from work area.
- Keep work area clean. Cluttered work areas invite accidents. Work area should be properly lit.
- Do not use power tools in dangerous environments. Do not use power tools in damp or wet locations. Do not expose power tools to rain.
- Wear proper apparel. Do not wear loose clothing, gloves, neckties, rings, bracelets or other jewelry which may get caught in moving parts of the tool.
- Wear protective hair covering to contain long hair.
- Wear safety shoes with non-slip soles.
- Wear safety glasses complying with United States ANSI Z87.1. Everyday glasses have only impact resistant lenses. They are NOT safety glasses.
- Wear face mask or dust mask if operation is dusty.
- Be alert and think clearly. Never operate power tools when tired, intoxicated or when taking medications that cause drowsiness.
- A guard or any other part that is damaged should be properly repaired or replaced. Do not perform makeshift repairs.
- Use the right tool for your job. Do not force your tool to do a job for which it was not designed.
- Use safety equipment such as featherboards, push sticks and push blocks, etc., when appropriate.
- Maintain proper footing at all times and do not overreach.
- Do not use the router table as a step or seat.

## WARNING

- To avoid serious injury, turn off and unplug the router before attaching the router base, changing accessories or adjusting the cutter height/fence position.
- Assemble the featherboard(s) at least 1" (2.5 cm) from the cutter to prevent kickback.
- Do not use the featherboard as a push block.

## CAUTION

Think safety! Safety is a combination of operator common sense and alertness at all times when tool is being used.

## WARNING

Do not use the router table fence until it is completely assembled and you have read and understood this entire operating manual and the operating manual of the tool being used with this router table fence.

**SAVE ALL WARNINGS AND INSTRUCTIONS  
FOR FUTURE REFERENCE**



1



## SPECIFIC SAFETY RULES

### DANGER

- To avoid serious injury, keep hands and fingers away from the spinning router bit. Be aware of the bit at all times.

### WARNING

#### AVOID THIS SITUATION!

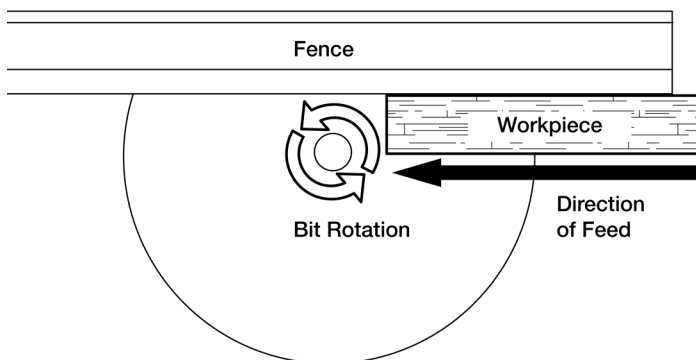

- NEVER FEED YOUR WORKPIECE BETWEEN THE BIT AND THE FENCE.** Because of the direction of the bit's rotation, the bit could "grab" the workpiece and propel it away from the table at a high velocity, potentially resulting in property damage and serious injury to anyone in its path.
- When the bit grabs the workpiece, your hands could be drawn into the bit, resulting in serious injury
- Turn off and unplug your router before installing or adjusting the bit or adjusting the router table fence and accessories.

- BEFORE** beginning any routing operation, **ALWAYS** make sure **ALL** knobs on the router table fence and accessories are tightened and the fence will not shift during use.
- Always feed the workpiece against the rotation of the bit. A table-mounted router spins the bit counterclockwise, so feed the workpiece from right to left as you face the table. This provides better control because the rotation of the bit is backward and toward the fence instead of forward and away from it.
- NEVER** attempt to machine a workpiece at the router table without using the router table fence or a starter pin with a bearing-guided bit. Failure to use these guides diminishes your ability to control the workpiece and greatly increases the chance of damage to the workpiece and/or serious personal injury.
- BEFORE** plugging in and turning on the router, always make sure the MDF adjustable fence faces are fully secured and the bit can rotate freely without touching the fence faces. An exception to this is if the infeed fence face is set to provide zero-clearance support for the workpiece, as described in the **Adjusting the Fence Faces** section.

### CAUTION

- Set the bit guard directly over the router bit, at least 1/2" above the top of the bit or the top of the workpiece (whichever is highest), make sure the bit doesn't cut into the bit guard.
- When adjusting the position of the router table fence, make sure no part of the aluminum fence will contact the router bit.



## UNPACKING

### Refer to Figure 1

Check for shipping damage. Check immediately whether all parts and accessories are included.

ITEM	DESCRIPTION	QTY
A	Fence	1
B	Fence lock knobs	2
C	Washers 5/16"	2
D	T-Bolt 5/16"-18 x 1"	2
E	MDF adjustable fence faces	2
F	Flat head screws 1/4"-20 x 1-1/2"	4
G	Washers 1/4"	4
H	Locking knobs	4
I	Bit guard	1
J	Bit guard knobs 1/4"	2
K	T-Bolts 1/4"-20 x 1"	2
L	Washers 1/4"	2
M	Router dust port	1
N	Pan head screws M4 x 10 mm	2
O	Washers 1/4"	2
P	Featherboard	1
Q	T-Bolts 5/16"-18 x 1-1/2"	2
R	Spacers	2
S	Locking knobs 5/16"	2
T	Tape measure with adhesive backing (right to left)	1
U	3" Flip stop	1
V	4 mm Round Rods	2
W	1/4" Square Rods	2

Figure 1

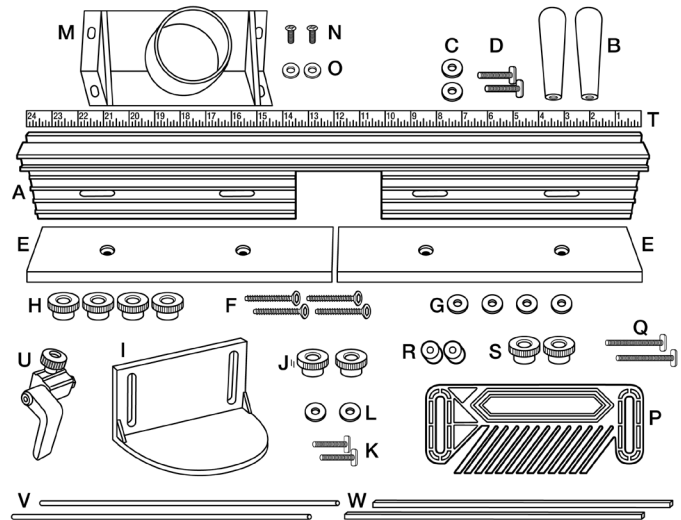

### **▲ WARNING**

Do not use the router table fence until it is completely assembled and you have read and understood this entire operating manual and the operating manual of the tool being used with this router table fence.



## ASSEMBLY

### Refer to Figure 2–4

- Remove the adhesive backing from the right to left tape measure and press into place. Start on the right end and carefully place the tape along the front edge of the fence. Use scissors to cut the excess tape from the left end.
- Attach the dust port to the back of the fence using the pan head screws and 1/4" washers.
- From the front of the MDF adjustable fence faces, insert the 1/4"-20 x 1-1/2" screws through the MDF adjustable fence face and fence, place a 1/4" washer over each screw and secure in place with the round locking knobs. The MDF adjustable fence faces can be adjusted left or right, after adjustment has been made for the operation to be performed, tighten all knobs securely.
- From the bottom of the fence insert the two 5/16"-18 x 1" T-Bolts through the fence slot. Place a 5/16" washer and fence locking knob on each T-Bolt. Place the fence onto the router table and align the T-Bolts in the fence with the slots in the router table. Tighten the knobs after adjusting the fence to the operation being performed.
- From the back of the bit guard insert the two 1/4"-20 x 1" T-Bolts, place 1/4" washers and round lock knobs on each T-Bolt. Place the T-Bolts into the T-Slot on the face of the fence and slide the bit guard onto the fence.

**NOTE:** To adjust the bit guard, loosen the knobs, slide the bit guard up and down to desired application and tighten knobs. When changing bits, slide the bit guard left or right of the opening.

### WARNING

To prevent kickback make sure the featherboard is at least 1" (2.5 cm) from the cutter.

- Place a spacer on each 5/16"-18 x 1-1/2" long T-Bolt and insert through the slot in the featherboard, thread a round locking knob on each T-Bolt and slide the T-Bolts into the T-slot in the front of the fence. Position the featherboard(s) and tighten locking knobs.
- Slide the T-Bolt on the flip stop into the T-Slot in top of the fence, tighten the knob. The arm on the flip stop functions as an easily adjustable stop and can be flipped up when not needed.

**NOTE:** The flip stop is multi-functional, please see flip stop instructions for details. To prevent chip build up, the stop does not extend the full width of the fence. However, when using a stop with material 3/8" thick or less, a longer stop will need to be fabricated and can be mounted in the T-slot located in the front of the fence.

**IMPORTANT:** Every routing operation is different, adjust the various parts of the router fence and accessories as needed and then tighten all knobs securely.

## ADJUSTING THE FENCE FACES

### Refer to Figure 5

The two MDF adjustable fence faces are designed to slide about 2" along the fence. This allows the opening for the router bit to be adjusted from 0" up to 4".

Generally, the infeed and outfeed adjustable fence faces should be adjusted as close to the bit as possible without contacting the cutter. This will help prevent the ends of the workpiece from drifting too far into the cutter at the beginning and end of the cut to provide quality and safe cut.

Sometimes the "zero-clearance" support is needed to deliver an even cleaner cut. In this case the router bit profile cuts into the front edge of the infeed adjustable fence face so there is virtually no gap between the cutter and the fence face. It delivers a cleaner cut because the workpiece fibers are fully supported throughout the cut.

If a zero-clearance setting is necessary, follow these steps:

1. Set the bit height and fence position. Set both of the MDF adjustable fence faces close to the bit without touching it, the fence faces **MUST NOT** contact the bit at this time.

### CAUTION

Set the bit guard directly over the router bit, at least 1/2" above the top of the bit or the top of the workpiece (whichever is highest), make sure the bit doesn't cut into the bit guard.

2. Install, adjust and secure the bit guard.
3. On the back of the fence, slightly loosen the locking knobs on the infeed MDF adjustable fence face. Start the router and slowly slide the infeed MDF adjustable fence face into the spinning router bit, stopping when the edge reaches the bit's guide bearing or midpoint (for bits that don't have a guide bearing).
4. Tighten the locking knobs on the back of the MDF adjustable fence face to secure it in position.

#### To Convert from Inboard to Outboard Position

Remove the knob and T-bolt and rotate the stop body 180°. Replace the knob and T-bolt. **See below**

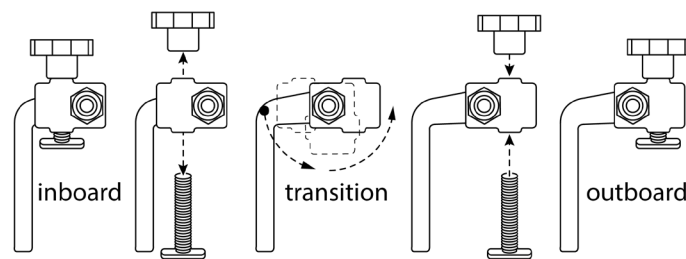

BACK

Figure 2

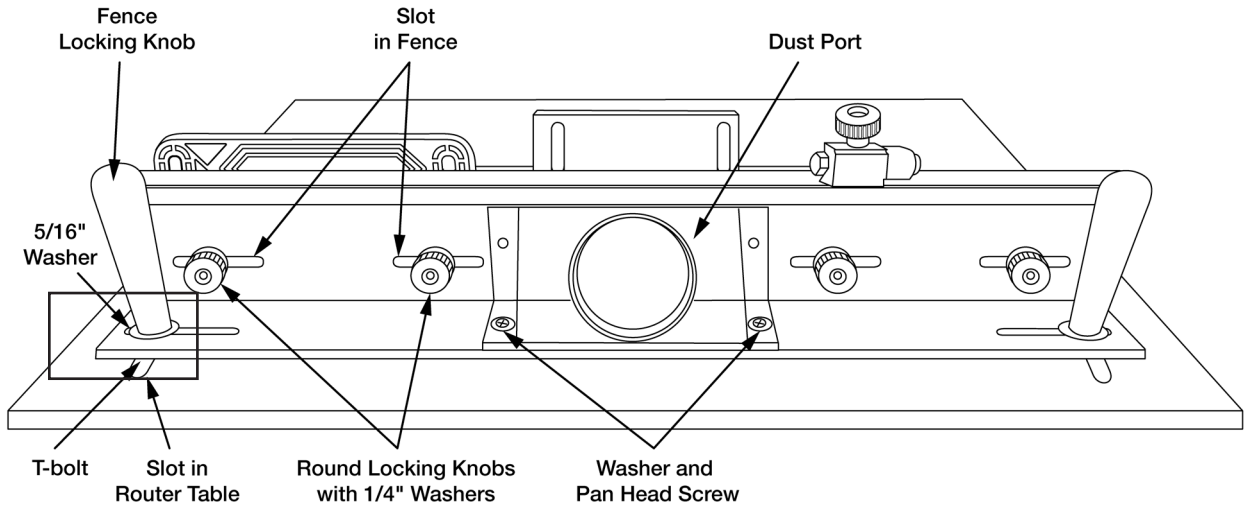

FRONT

Figure 3

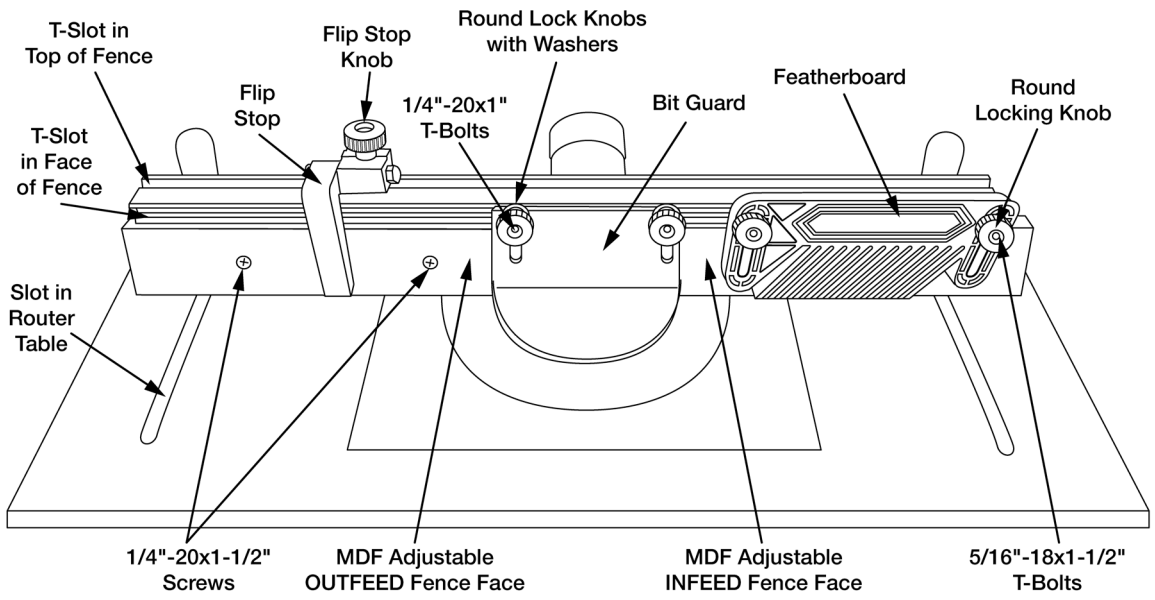

Figure 4

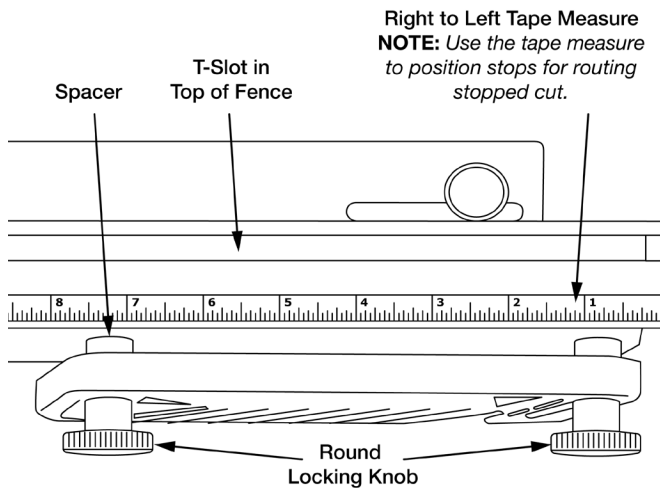
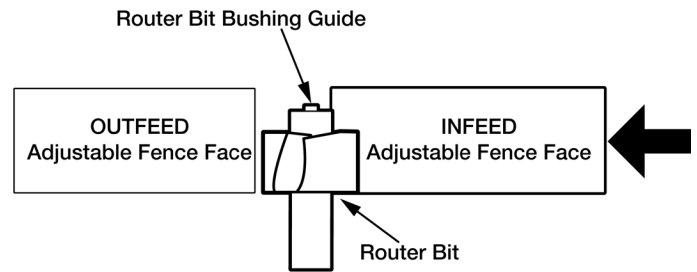

Figure 5





## JOINTING

## Refer to Figure 6–9

The independently adjustable fence faces allow the router table to be used as a vertical jointer by offsetting the outfeed fence face  $3/128$ ",  $1/16$ ",  $5/64$ " from the infeed fence face.

Two sets of grooves are located in the fence behind the fence faces, slide the jointing rods into these grooves to offset the outfeed fence face  $3/128$ ",  $1/16$ ",  $5/64$ " from the infeed fence face.

- Loosen the round locking knobs securing the outfeed fence face. Slide the jointing rods into the desired groove on the fence.
  - For a  $5/64$ " offset slide the square jointing rods into the square grooves on the outfeed fence. **See Figure 6.**
  - For a  $1/16$ " offset, slide the round jointing rods into the round grooves on the outfeed fence. **See Figure 7.**
  - For a  $3/128$ " offset, slide the round jointing rods into the round grooves on the infeed fence and slide the square rods into the square grooves on the outfeed fence. **See Figure 8.**

Figure 6

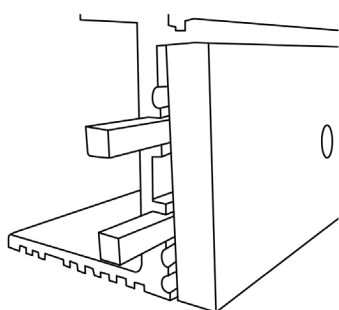

Square Jointing Rods Shown in Square Grooves

Figure 7

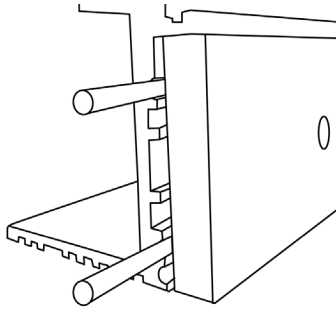

Round Jointing Rods Shown in Round Grooves

Figure 8

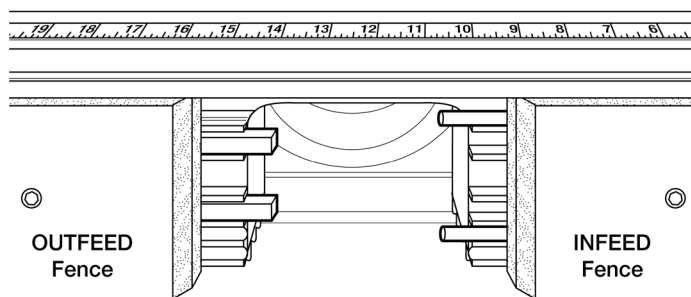
Square Jointing Rods Shown in the Square Grooves on the Outfeed Fence and the Round Jointing Rods in the Round Grooves on the Infeed Fence for the  $3/128$ " Offset

**NOTE:** It is best to make light passes when jointing, the  $3/128$ " and  $1/16$ " offset will be used more frequently than the  $5/64$ " offset.

- With the rods in place, tighten the fence face locking knobs.

Figure 9

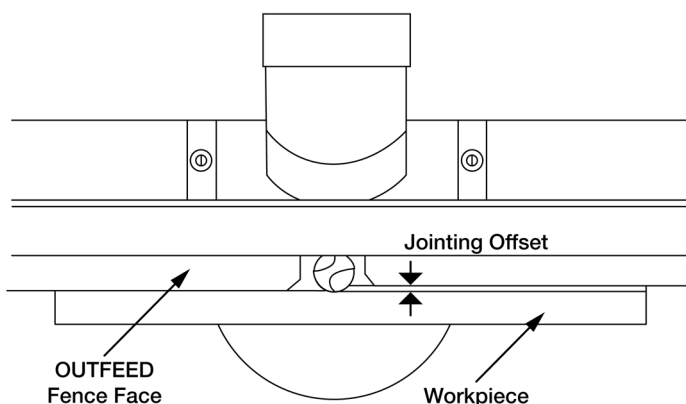

- Install a straight bit in the router. Place a straight edge against the outfeed fence face and position the fence so the bit just grazes the straight edge.

**NOTE:** Make sure all rods are clear of cutter.

**NOTE:** Any straight bit can be used for jointing. A flush-trim bit is the easiest to set up because the bit guide bearing is the same diameter as the cutter and it can be aligned to the outfeed fence face with the bearing. An up-cut spiral bit produces an almost chatter-free surface, but it is more difficult to align with the fence face.

Always use a scrap piece of wood to test the setup.

- If the scrap is fed past the bit and it runs into the leading end of the outfeed fence face, the fence is too far forward and not enough material is being removed. Move the fence back a little.
- If there is snipe at the trailing edge of the scrap, the fence is too far back and too much material is being removed. Move the fence forward.



## GENERAL MAINTENANCE

**WARNING**

When servicing, use only identical replacement parts. Use of any other parts may create a hazard or cause product damage. To ensure safety and reliability, all repairs should be performed by a qualified service technician.

**WARNING**

Keep the router table fence dry, clean, and free from oil and grease. Always use a clean cloth when cleaning. Never use brake fluids, gasoline, petroleum-based products or any strong solvent to clean the router table fence. Chemicals can damage, weaken or destroy plastic which may result in serious personal injury.







A series of horizontal lines for writing notes, starting from the top of the page and extending to the bottom. The lines are evenly spaced and cover the majority of the page's width.

Thank you for investing in a **POWERTEC** power tool. This product has been designed and manufactured to meet high quality standards and is guaranteed for domestic use against defects in workmanship or material for a period of 12 months from the date of purchase. This guarantee does not affect your statutory rights.

### **SOUTHERN TECHNOLOGIES LLC. BENCH TOP AND STATIONARY POWER TOOL LIMITED 1 YEAR WARRANTY AND 30-DAY SATISFACTION GUARANTEE POLICY**

**POWERTEC** products are designed and manufactured by **Southern Technologies LLC**. All warranty communications should be directed to **Southern Technologies LLC** by calling 847-780-6120 (toll free), 9 AM to 5 PM, Monday through Friday, US Pacific Time.

#### **30- DAY SATISFACTION GUARANTEE POLICY**

During the first 30 days after the date of purchase, if you are dissatisfied with the performance of this **POWERTEC** tool for any reason, you may return the tool to the retailer from which it was purchased for a full refund or exchange. You must present proof of purchase and return all original equipment packaged with the original product. The replacement tool will be covered by the limited warranty for the balance of the one year warranty period.

#### **LIMITED ONE YEAR WARRANTY**

This warranty covers all defects in workmanship or materials in this **POWERTEC** tool for a one year period from the date of purchase. This warranty is specific to this tool. **Southern Technologies, LLC** reserves the right to repair or replace the defective tool, at its discretion.

#### **HOW TO OBTAIN SERVICE**

To obtain service for this **POWERTEC** tool you must return it, freight prepaid, to **POWERTEC**. You may call (toll free) 847-780-6120 for more information. When requesting warranty service, you must present the proof of purchase documentation, which includes a date of purchase. **POWERTEC** will either repair or replace any defective part, at our option at no charge to you. The repaired or replacement unit will be covered by the same limited warranty for the balance of one year warranty period.

#### **WHAT IS NOT COVERED**

This warranty applies to the original purchaser at retailer and may not be transferred.

This warranty does not cover consumable items such as saw blades, knives, belts, discs, cooling blocks, and sleeves. This warranty does not cover required service and part replacement resulting from normal wear and tear, including accessory wear.

This warranty does not cover any malfunction, failure or defect resulting from:

- 1) misuse, abuse, neglect and mishandling not in accordance with the owner's manual.
- 2) damage due to accidents, natural disasters, power outage, or power overload.
- 3) commercial or rental use.
- 4) alteration, modification or repair performed by persons not recommended by **POWERTEC**.

#### **DISCLAIMER**

To the extent permitted by applicable law, all implied warranties, including warranties of MERCHANTABILITY or FITNESS FOR A PARTICULAR PURPOSE, are disclaimed. Any implied warranties, that cannot be disclaimed under state law are limited to one year from the date of purchase. **Southern Technologies LLC**. is not responsible for direct, indirect, incidental or consequential damages. Some states do not allow limitations on how long an implied warranty lasts and/or do not allow the exclusion or limitation of incidental or consequential damages, so the above limitations may not apply to you. This warranty gives you specific legal rights, and you may also have other rights which vary from state to state. Southern Technologies LLC., makes no warranties, representations, or promises as to the quality or performance of its power tools other than those specifically stated in this warranty.

***POWERTEC***®

Southern Technologies, LLC  
Chicago, IL 60606