

**Quick Release Framing Clamp**



**PACKAGING CONTENTS**

- 4—Spindles
- 4—Corner Blocks
- 4—Quick Nuts
- 4—Keeper Knobs
- 4—Extension Spindles (extra spindles for larger frames)
- 4—Extension Nuts

Figure 1

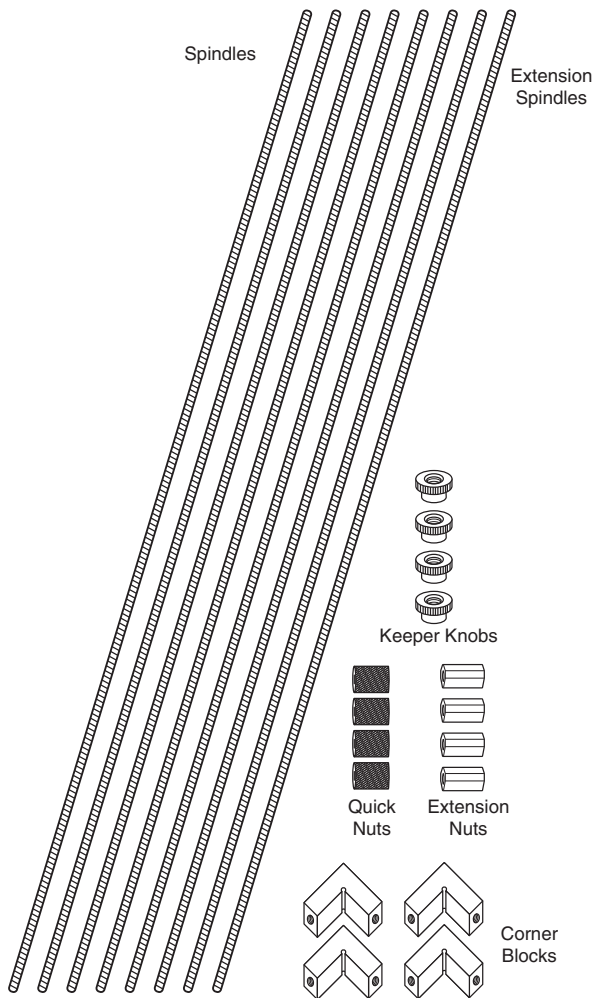

**TO ASSEMBLE**

1. Thread one end of a spindle into each of the four corner blocks.

Figure 2

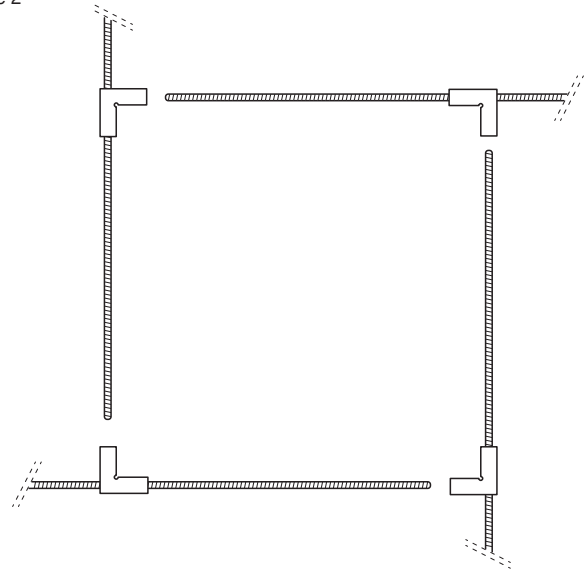

2. Form a square or rectangle by placing the free end of each spindle through the free end of each corner block.

Figure 3

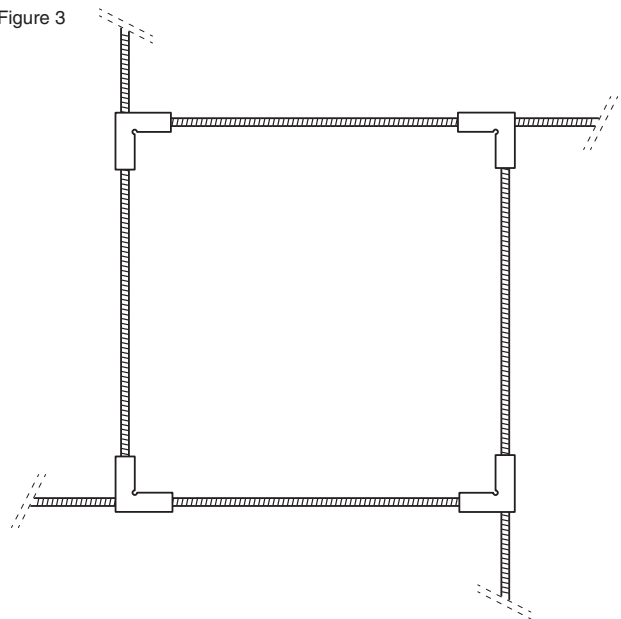

3. Tilt the quick nut and slide it onto the spindle. **DO NOT** engage the threads at this time. Thread the keeper knobs onto each spindle to keep the quick nuts from sliding off spindle.

Figure 4

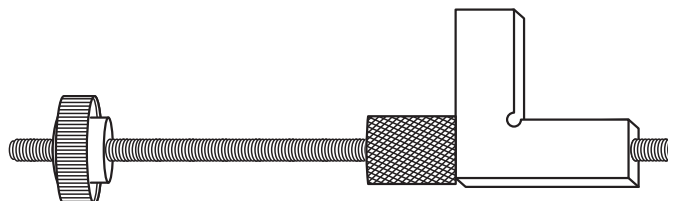

4. To clamp the four mitered pieces:
- Place the four mitered pieces into the opening of the assembled clamp.
  - Tilt and slide the quick nut into position, square up the quick nut and engage the threads. Tighten in place.

Figure 5

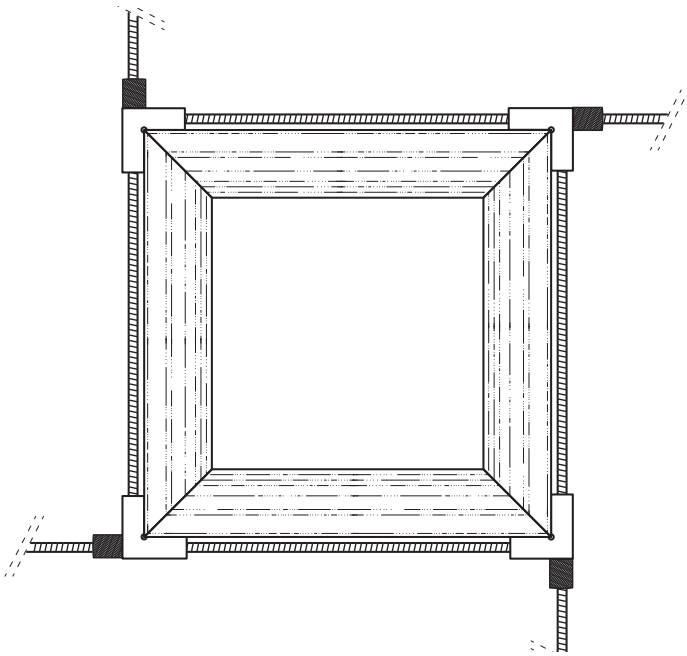

**NOTE:** For larger frames (up to 4' x 4') add the extension spindles using the extension nuts.

Figure 6

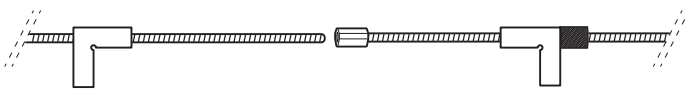

Visit us on the web at [www.powertecproducts.com](http://www.powertecproducts.com)



Put these instructions and the original sales invoice in a safe, dry place for future reference.

Southern Technologies, LLC  
Waukegan, IL 60087