

Owner's Manual

POWERTEC

Taper / Straight Jig

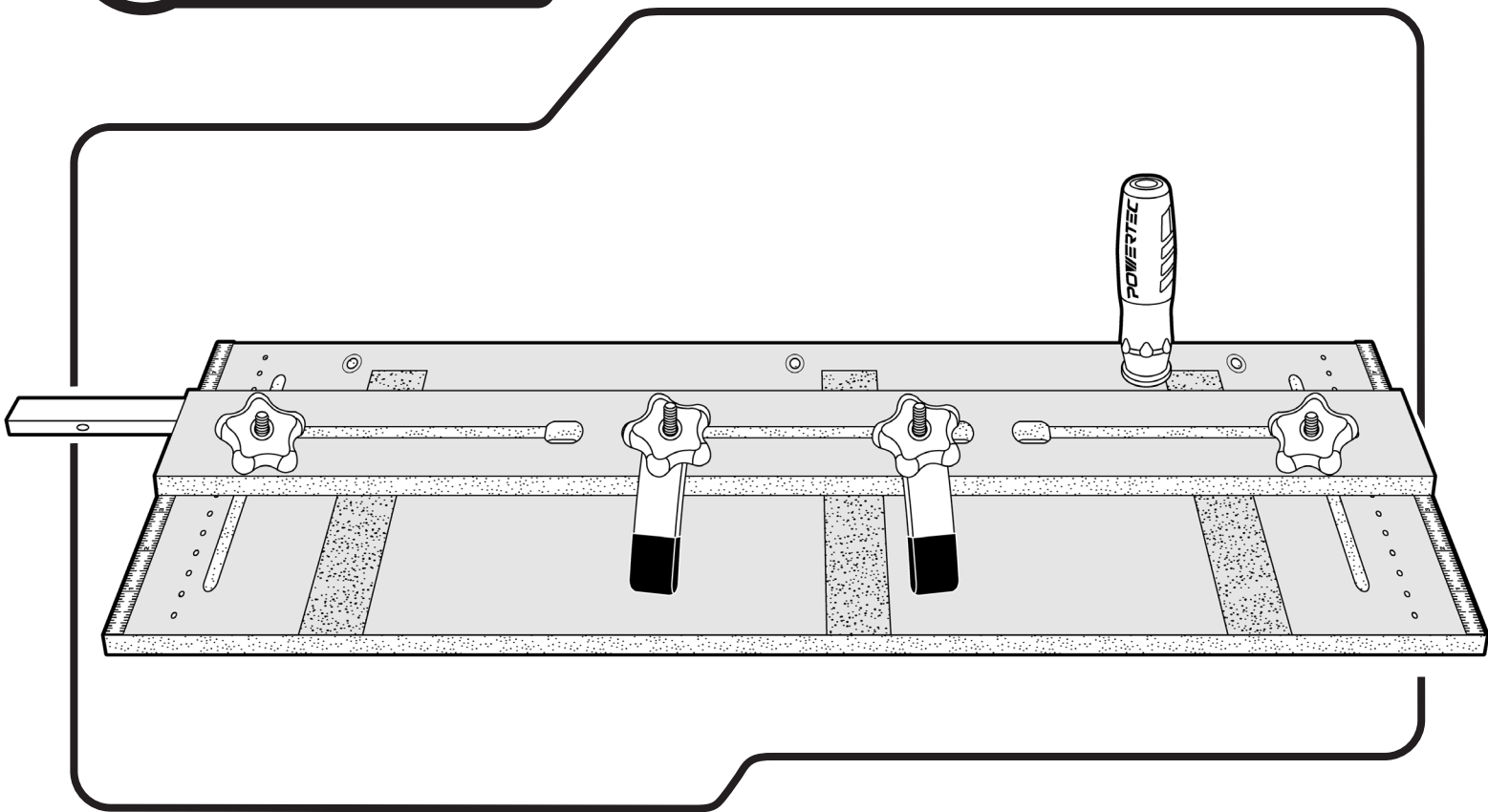







Visit us on the web at www.powertecproducts.com



You will need this manual for safety instructions, operating procedures, and warranty. Put it and the original sales invoice in a safe, dry place for future reference.

TABLE OF CONTENTS

SECTION	PAGE
 SAFETY RULES	0-1
Safety Rules	
 PARTS AND CONTENTS	1
Unpacking	
 ASSEMBLY	2
Assembly	
 OPERATION	3-4
Operation Adjustments	
 MAINTENANCE	4
General Maintenance	
 WARRANTY	5
Warranty	

PRODUCT SPECIFICATIONS

Base (MDF)	32" x 7-7/8" x 1/2"
MDF Adjustable Fence	32" x 2-1/2" x 1"
Miter Bar (Aluminum)	36" x 3/4" x 3/8"

GENERAL SAFETY RULES

For your own safety, read all of the rules and precautions before operating tool.

WARNING

Always follow proper operating procedures as defined in this manual even if you are familiar with use of this jig or any tool used with this jig. Remember that being careless for even a fraction of a second can result in severe personal injury.

Before using another tool with this product, always read, understand and follow the instructions and safety warnings in the owner's manual for that tool. If you do not have the owner's manual, obtain one from the tool's manufacturer before using it with this product.

You must be familiar with the use of any tool or accessory used with this jig. The supplier cannot be held responsible for any accident, injury or damage incurred while using this jig with any tool.

It is the responsibility of the purchaser of this product to ensure that any person using this product reads and complies with all instructions and safety precautions outlined in this manual and the operating manual of the tool being used prior to use.

WARNING

Some dust created by operation of power tool contains chemicals known to the State of California to cause cancer, birth defects or other reproductive harm. To reduce your exposure to these chemicals, work in a well ventilated area and work with approved safety equipment. Always wear OSHA/NIOSH approved, properly fitting face mask or respirator when using such tools.

WARNING

Do not modify or use this jig for any application other than that for which it was designed.

FOLLOW ALL STANDARD SHOP SAFETY PRECAUTIONS, INCLUDING:

- Keep children and visitors at a safe distance from work area.
- Keep work area clean. Cluttered work areas invite accidents. Work area should be properly lit.
- Do not use power tools in dangerous environments. Do not use power tools in damp or wet locations. Do not expose power tools to rain.
- **TURN OFF AND UNPLUG** all power tools **BEFORE** making any adjustments or changing accessories.
- Be alert and think clearly. Never operate power tools when tired, intoxicated or when taking medications that cause drowsiness.
- Wear proper apparel. Do not wear loose clothing, gloves, neckties, rings, bracelets or other jewelry which may get caught in moving parts of the tool.
- Wear protective hair covering to contain long hair.
- Wear safety shoes with non-slip soles.
- Wear safety glasses complying with United States ANSI Z87.1. Everyday glasses have only impact resistant lenses. They are **NOT** safety glasses.
- Wear face mask or dust mask if operation is dusty.
- A guard or any other part that is damaged should be properly repaired or replaced. Do not perform makeshift repairs.

- Use safety equipment such as featherboards, push sticks and push blocks, etc., when appropriate.
- Maintain proper footing at all times and do not overreach.
- Do not force woodworking tools.

CAUTION

- Think safety! Safety is a combination of operator common sense and alertness at all times when tool is being used.

WARNING

- Do not use the jig until it is completely assembled and you have read and understood this entire operating manual and the operating manual of the tool being used with this jig.

SPECIFIC SAFETY WARNINGS



DANGER

Risk of serious bodily injury. Keep hands out of the path of the spinning blade. Maintain awareness of the blade at all times.

Always turn off and unplug the saw when making any adjustments

WARNING

- The jig is intended for use on table saws with a standard 3/8"D x 3/4"W miter slot.
- During setup, the jig may need to be cut to fit your specific saw. Read the instructions carefully to complete this essential setup step.
- The hold-down clamps MUST be positioned so they will NOT come into contact with saw blade.
- You MUST tighten all knobs and the hold down to secure the workpiece after making any adjustments and before making any cuts.
- Keep the saw blade as low as possible to make the cut, as defined by your table saw's instruction manual.

- Before making the actual cut, become familiar with the cutting process by practicing the motion of the cut with the blade lowered and the power turned off.
- Make sure there is sufficient out-feed support when cutting long pieces.
- Do NOT attempt to cut pieces that are too narrow to be secured to the jig with the hold-down clamps.
- The jig handle must be installed when making all taper and straight cuts.
- The miter bar MUST be installed on the jig when making taper cuts.
- When making taper cuts, position the miter bar in the miter slot on the right side of the blade. See instructions for Miter Bar Fine Adjustments.
- DO NOT use the table saw fence when making taper cuts.
- The adjustable stop on the jig fence MUST be used during taper and straight cuts. Make sure it is adjusted so it DOES NOT come in contact with the blade and is tightened securely.
- Remove the miter bar and use the jig with the table saw fence when making straight cuts. ALWAYS reassemble the miter bar before making taper cuts with the jig.

SAVE ALL WARNINGS AND INSTRUCTIONS FOR FUTURE REFERENCE

PARTS AND CONTENT



UNPACKING

Refer to Figure 1

Check for shipping damage. Check immediately whether all parts and accessories are included.

ITEM	DESCRIPTION	QTY
A	Base (MDF)	1
B	Adjustable Fence with Stop Plate	1
C	Aluminum Miter Bar	1
D	Handle (4-1/2" long)	1
E	Hold Down Clamps (5-1/2" long)	2
F	Five Star knobs	4
G	T-Bolts, 5/16"-18 x 2-1/2"	2
H	Tape Measure with Self-Adhesive Back	2
I	Abrasive Grip Strips, 1-1/2" x 7"	3
J	Flat Head Screw, 5/16"-18 x 1"	1
K	Screw, 1/4"-20 x 3/4"	3
L	Washers, 5/16"	5
M	Nylon Adjustment Screws, #10-32	9
N	Small Screwdriver	1
O	T-Bolts, 5/16"-18 x 3-1/2"	2

Figure 1

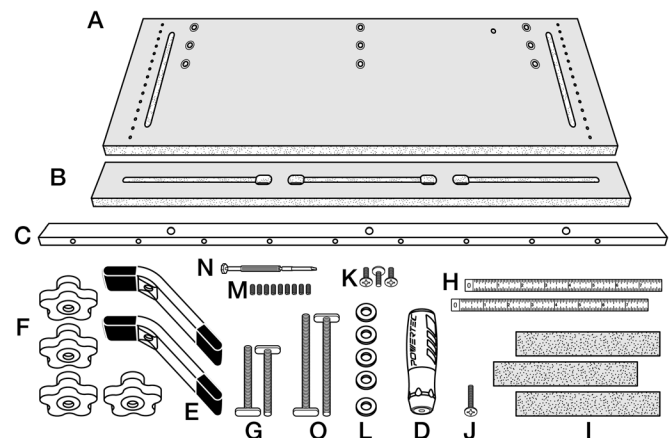

WARNING

Do not use the jig until it is completely assembled and you have read and understood this entire operating manual and the operating manual of the tool being used with this jig.





ASSEMBLY

Miter Bar and Handle

The miter bar is used when making taper cuts only. **The miter bar MUST be removed when straight line ripping.**

NOTE: When making taper cuts, the jig is used in the miter slot to the right of the blade for taper cutting. On some saws the initial cut will remove a narrow piece of the jig's base to create zero-clearance support.

1. See Figure 2. Assemble the nine slotted nylon adjustment screws into the miter bar. Do not tighten, adjustment will be made later.
2. Use the three 1/4"-20 x 3/4" screws to assemble the miter bar to the bottom of the base. The miter bar is longer than the base, position the extended portion away from the operator.

NOTE: There are three sets of mounting holes for the miter bar, use the set of holes that will result in the least amount of stock being removed during the initial cut.

Figure 2

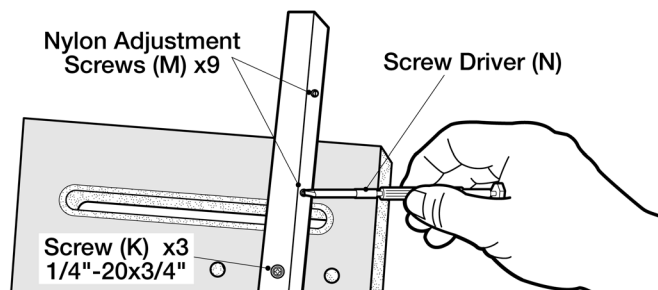

3. See Figure 3. From the underneath the base, insert the 5/16"-18 x 1" flat head screw through the hole near the rear edge of the base. Place a washer onto the screw and thread on the Handle. Tighten the handle.

Figure 3

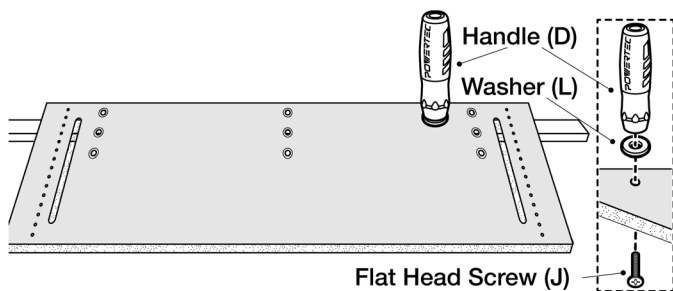

4. Make sure the table saw's blade is parallel to the table's miter slot and 90° to the table. If it isn't, follow the saw manufacturer's guidelines to make necessary adjustments so it is parallel to the miter slots and square to the table.
5. Lower the blade below the table surface.

Miter Bar Adjustment

⚠ WARNING

The miter bar **MUST** be able to slide freely forward and backward without side-to-side play. **NEVER** attempt to force the crosscut sled if it fails to slide freely.

- Place the miter bar on the jig into the right miter slot of the table saw and slide to evaluate the fit. The jig should slide easily with no side to side shift.
- **If adjustments are needed:** Remove the jig—turn it over. Use the small screwdriver provided to adjust the nylon screws (See Figure 2). Make necessary adjustments until the jig slides easily with no side to side shift.

Trim the Base to Fit the Table Saw Being Used

NOTE: Some saws will not require the jig/base to be trimmed. When the jig is placed in the miter slot any excess material will need to be trimmed from the base.

NOTE: The jig is used in the miter slot to the right of the blade for taper cutting.

1. Place the base on the saw's table with the miter bar in the miter slot and clear of the blade. See the Miter Bar Adjustment instructions, if needed.
2. Pull the jig back until it is clear of the cutting area, turn on the saw, raise the blade and then push the jig through the blade to make the cut to trim the jig's base to create a zero-clearance edge.

Figure 4

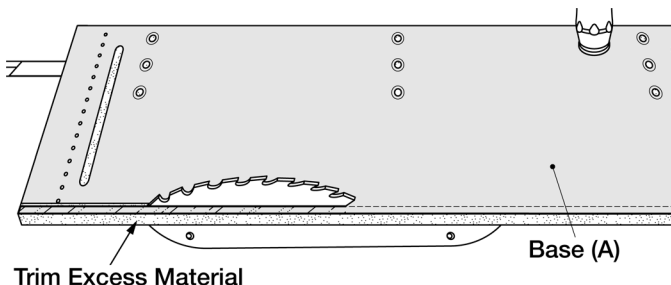

Apply Tape Measures and Abrasive Grip Strips

1. Remove the adhesive backing from the tape measures and press into place at each end of the base. Align the "0" on the tape measures with the zero-clearance edge. Use scissors to cut the excess tape.
2. Remove the adhesive backing from the abrasive grip strips and press onto the base, align the strips to the zero-clearance edge as shown. **DO NOT** cover up the miter bar screws.

Figure 5

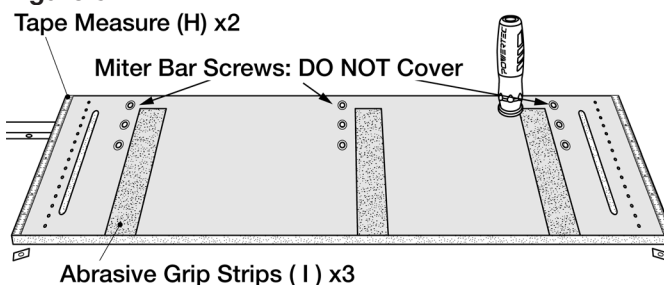

Attach Hold Down Clamps and Adjustable Fence

[1] See Figure 6. Attach the adjustable fence to the base:

- From underneath base, insert **2-1/2" x 5/16"-18 T-Bolt (G)** through slot in base and slot in adjustable fence. Secure in place with Washer (L) and Five Star Knob (F). Repeat on other side.

[2] Attach two Hold-down Clamps (E) to adjustable fence. For each hold-down clamp:

- Place Hold Down Clamp (E) onto a **3-1/2" x 5/16"-18 T-Bolt (O)**. Place T-Bolt into one of the keyholes in the top of the fence and slide along the T-slot. Secure in place with Washer (L) and Five Star Knob (F).

NOTE: The hold-down clamps can be positioned in any of the three slots, depending on the clamping requirements.

[3] **DO NOT** use the table saw fence when making a taper cut.

Figure 6

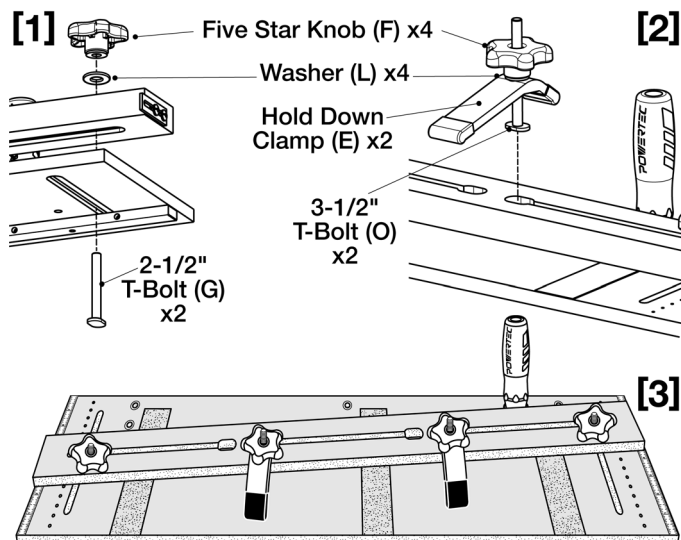

TO USE:

DANGER

Risk of serious bodily injury. Keep hands out of the path of the spinning blade. Maintain awareness of the blade at all times.

Always turn off and unplug the saw when making any adjustments.

WARNING

- For your own safety, read all of the rules and precautions before operating tool.
- Tighten all knobs and hold downs securing the workpiece after making any adjustments and before making any cuts.

NOTE: The Taper Jig **will fit** full sized table saws with miter slots 3/4" x 3/8" and with inside edge of right miter slot between 3-3/4" to 4-3/8" or 5" to 5-5/8" or 6-1/4" to 6-7/8" from the blade.

The Taper Jig **may not** be compatible with many job sit or bench top saws. Please check the saw before ordering.

Taper Cutting

Refer to Figure 7-9

DO NOT use the table saw fence when making a taper cut.

1. See Figure 7. Slide the miter bar into the saw's miter slot and position the jig at the front of the saw, clear of the blade. See the Miter Bar Adjustment instructions, if needed.
2. Set the adjustable fence to the desired taper. There are three ways to set the taper angle.
 - Use the indexing marks located at both ends of the base. This will set the degree of the taper. The distance between each mark represents 1 degree of taper.
 - **Example:** If the adjustable fence is set at the sixth mark from the left at the front of the jig base and at the fourth mark from the left rear, the taper will be a 2 degree taper.
 - Use the tape measures to set the beginning and ending widths of the taper.

Figure 7

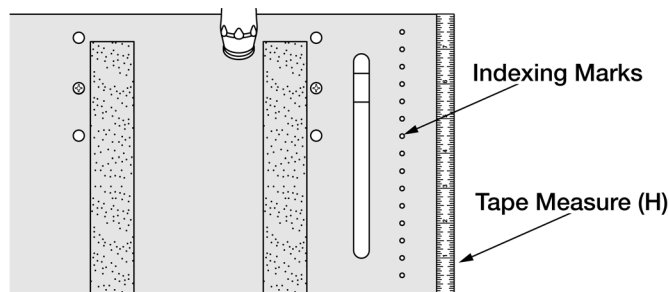

- Use the stock/workpiece: Mark the beginning and ending on the stock and align these marks with the zero-clearance edge.
3. Tighten the five star knobs on each end of the adjustable fence to secure in place.
 4. See Figure 8. Place the workpiece tight against the adjustable fence with the eventual narrow end flush against the adjustable stop on the fence. Position the adjustable stop so it will support the workpiece but will not come in contact with the blade during the cut. Make sure the screws are tightened.

Figure 8

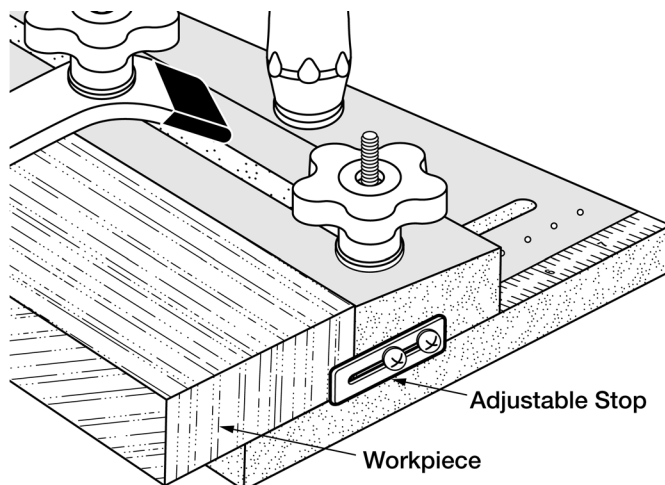

5. See Figure 9. Position the hold down clamps along the workpiece. Make sure they will not come in contact with the saw blade, guard or riving knife during the cut. Tighten the five star knobs to secure the workpiece. DO NOT try to cut pieces that are too narrow to be secured by the hold down clamps.
6. With the saw turned off, lower the blade and practice the cut using the handle to push the jig forward. Make any needed adjustments and tighten all knobs.
7. Return the jig to the starting position, raise the blade, turn on the saw and slowly advance the jig to make the cut. Once the cut is made, turn off the saw and allow the blade to stop spinning before returning the jig to the starting position.

4 **Figure 9**

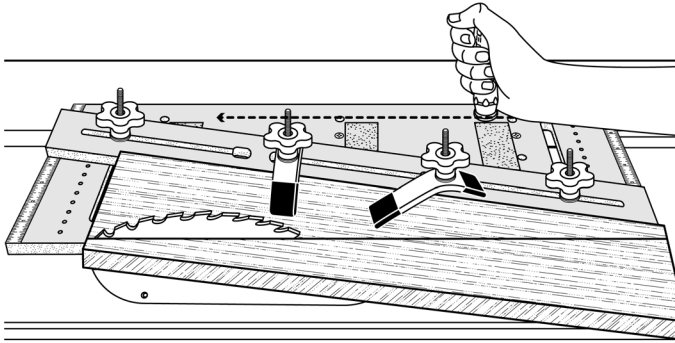

GENERAL MAINTENANCE

WARNING

When servicing, use only identical replacement parts. Use of any other parts may create a hazard or cause product damage. To ensure safety and reliability, all repairs should be performed by a qualified service technician.

WARNING

Keep the jig dry, clean, and free from oil and grease. Always use a clean cloth when cleaning. Never use brake fluids, gasoline, petroleum based products or any strong solvent to clean the jig. Chemicals can damage, weaken or destroy plastic which may result in serious personal injury.

Straight Line Ripping Refer to Figure 10

The miter bar **MUST** be removed when straight line ripping.

1. Remove the miter bar from the jig base. The table saw's fence is used to set the cutting width and guide the cut.
2. Loosen the five star knobs on each end of the adjustable fence and position it parallel to the jig's long edges. Tighten the knobs. If needed, retract the adjustable stop.
3. Place the workpiece against the jig. Position the hold down clamps along the workpiece. Make sure they will not come in contact with the saw blade, guard or riving knife during the cut. Tighten the five star knobs to secure the workpiece. DO NOT try to cut pieces that are too narrow to be secured by the hold down clamps.
4. Position the long side of the jig tight against the table saw's fence and make the cut. Keep the jig tight against the fence as the workpiece is fed into the blade.

Figure 10

Align Base (A) Flush Against Fence

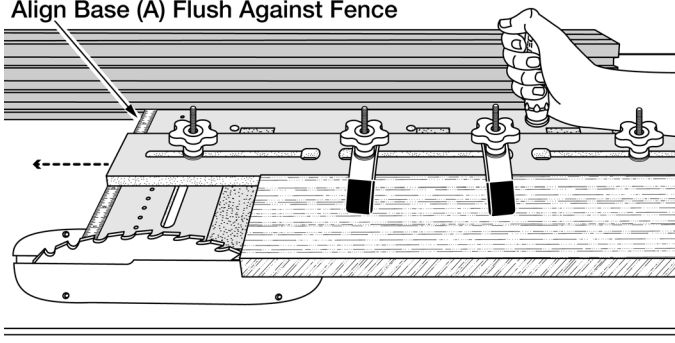

Thank you for investing in a **POWERTEC** power tool. This product has been designed and manufactured to meet high quality standards and is guaranteed for domestic use against defects in workmanship or material for a period of 12 months from the date of purchase. This guarantee does not affect your statutory rights.

**SOUTHERN TECHNOLOGIES LLC. BENCH TOP AND STATIONARY POWER TOOL
LIMITED 1 YEAR WARRANTY AND 30-DAY SATISFACTION GUARANTEE POLICY**

POWERTEC products are designed and manufactured by **Southern Technologies LLC**. All warranty communications should be directed to **Southern Technologies LLC** by calling 847-780-6120 (toll free), 9 AM to 5 PM, Monday through Friday, US Pacific Time.

30- DAY SATISFACTION GUARANTEE POLICY

During the first 30 days after the date of purchase, if you are dissatisfied with the performance of this **POWERTEC** tool for any reason, you may return the tool to the retailer from which it was purchased for a full refund or exchange. You must present proof of purchase and return all original equipment packaged with the original product. The replacement tool will be covered by the limited warranty for the balance of the one year warranty period.

LIMITED ONE YEAR WARRANTY

This warranty covers all defects in workmanship or materials in this **POWERTEC** tool for a one year period from the date of purchase. This warranty is specific to this tool. **Southern Technologies, LLC** reserves the right to repair or replace the defective tool, at its discretion.

HOW TO OBTAIN SERVICE

To obtain service for this **POWERTEC** tool you must return it, freight prepaid, to **POWERTEC**. You may call (toll free) 847-780-6120 for more information. When requesting warranty service, you must present the proof of purchase documentation, which includes a date of purchase. **POWERTEC** will either repair or replace any defective part, at our option at no charge to you. The repaired or replacement unit will be covered by the same limited warranty for the balance of one year warranty period.

WHAT IS NOT COVERED

This warranty applies to the original purchaser at retailer and may not be transferred.

This warranty does not cover consumable items such as saw blades, knives, belts, discs, cooling blocks, and sleeves. This warranty does not cover required service and part replacement resulting from normal wear and tear, including accessory wear.

This warranty does not cover any malfunction, failure or defect resulting from:

- 1) Misuse, abuse, neglect and mishandling not in accordance with the owner's manual.
- 2) Damage due to accidents, natural disasters, power outage, or power overload.
- 3) Commercial or rental use.
- 4) Alteration, modification or repair performed by persons not recommended by **POWERTEC**.

DISCLAIMER

To the extent permitted by applicable law, all implied warranties, including warranties of MERCHANTABILITY or FITNESS FOR A PARTICULAR PURPOSE, are disclaimed. Any implied warranties, that cannot be disclaimed under state law are limited to one year from the date of purchase. **Southern Technologies LLC**. is not responsible for direct, indirect, incidental or consequential damages. Some states do not allow limitations on how long an implied warranty lasts and/or do not allow the exclusion or limitation of incidental or consequential damages, so the above limitations may not apply to you. This warranty gives you specific legal rights, and you may also have other rights which vary from state to state. Southern Technologies LLC., makes no warranties, representations, or promises as to the quality or performance of its power tools other than those specifically stated in this warranty.

POWERTEC®

Southern Technologies LLC • Chicago • IL 60606