

INSTRUCTION SHEET

DuBois®

Model No. 51023

3" Fence Flip Stop with 1/4" T-Bolt

Model No. 51034

3" Fence Flip Stop with 1/4" Hex Bolt



PACKAGING CONTENTS

Fence Flip Stop (one set)

TO USE

51023: This fence flip stop works with most brands of Universal T-Tracks accepting 1/4" T-Bolts.

51034: This fence flip stop works with most brands of 1/4" T-Tracks accepting 1/4" hex bolts.

These Fence Flip Stops are extremely versatile and can be used with or without a sacrificial board. In addition, the flip arm can be moved from right to left to match your feed direction requirements.

- When working with single wide multi track fences, simply flip the arm down and use as an easily adjustable stop. See Figure 1.

Figure 1

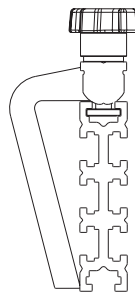

- When working with wider fences or using a sacrificial board, the angle of the specially designed arm accommodates for the extra 3/4" width and flips down. No conversion or adjustment is required. See Figure 2.

Figure 2

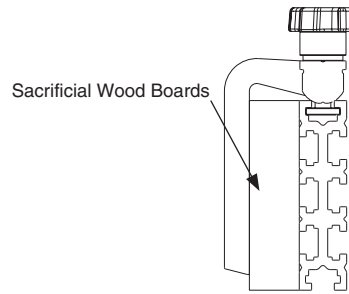

Assembly

Slide the T-Bolt (51023) or hex bolt (51034) into the slot on the top of the fence. Position the arm as needed and tighten the knob. When clamped, the unique cylindrical shape of the body wedges into the top of the T-Track. This allows these flip stops to work with different size of T-Tracks and eliminates slack or movement.

Figure 3

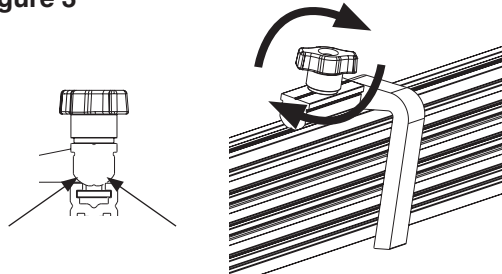

To Move the Flip Arm

Use a 5 mm hex wrench to remove the bolt and reposition the flip arm assembly to the required side of the body. Make sure nylon washer is between the flip arm and body and replace bolt. See Figure 4.

Figure 4

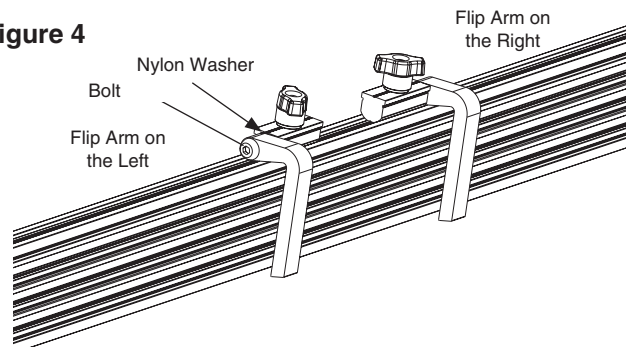

Visit us on the web at www.powertecproducts.com



Put these instructions and the original sales invoice in a safe, dry place for future reference.

Southern Technologies, LLC
Chicago, IL 60606