

INSTRUCTION SHEET
POWERTEC
FOLDING SAWHORSE

Model No. UT1005



PACKAGING CONTENTS

1 - Fully assembled sawhorse

TO SET UP

- Place saw horse on a flat surface and rotate each set of legs into the vertical position.
- Rotate the individual legs out until they hit the stop and are held in place by the locking tab.

Figure 1

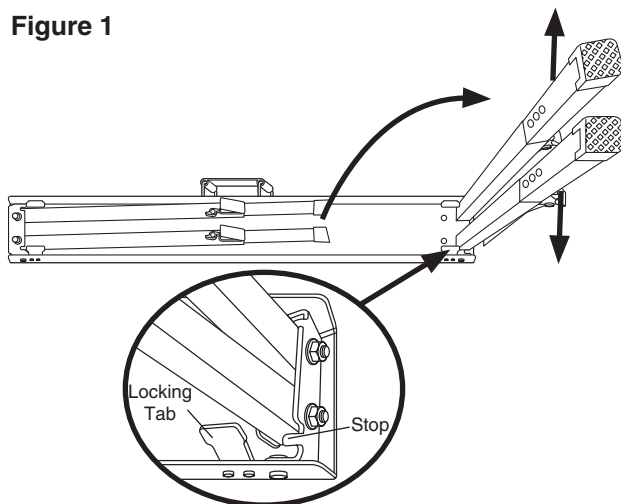

- Swing the lock bar up and slide it under the locking knob, then tighten locking knob to secure. Repeat on other side.



PINCH HAZARD! Keep hands and fingers clear.

- Press and hold the leg-lock lever to extend and telescope the legs to the desired position.
- Release the leg-lock lever into the numbered slot on the leg. Each leg has twelve positions. Repeat for each leg.

Figure 2

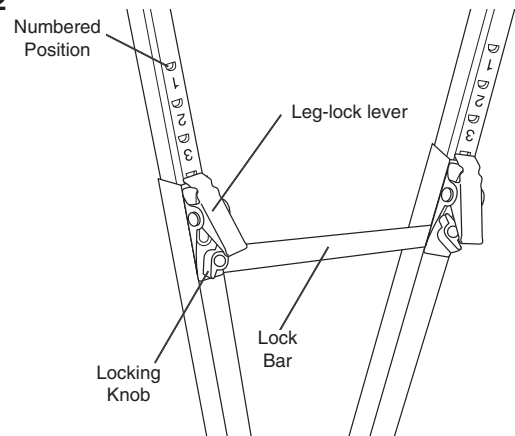

- Place the saw horse in the upright position.

Figure 3

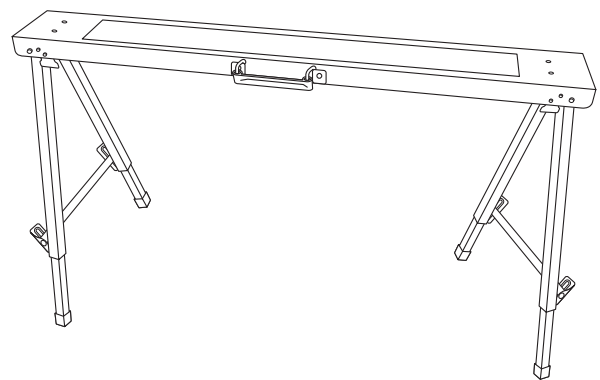

TO FOLD FOR STORAGE

- Place the saw horse upside down on a flat surface.
- Press the leg-lock lever and set each leg to the lowest position.
- Loosen locking knobs and swing lock bars down.
- Rotate the individual legs away from the stops and locking tabs.
- Fold the leg-sets down inside the top and space the legs as shown in Figure 4.

Figure 4

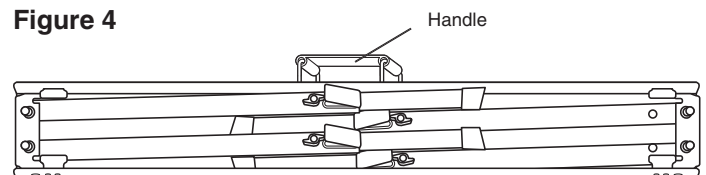

- Use the handle to lift and move the sawhorse to storage.

Visit us on the web at www.southerntechllc.com



Put these instructions along with the original sales invoice in a secure location for future reference.

Southern Technologies, LLC
 3816 Hawthorn CT
 Waukegan, IL 60087