

Owner's Manual

POWERTEC

UNIVERSAL STAND

? QUESTION...
1-877-393-7121







Visit us on the web at www.southerntechllc.com



You will need this manual for safety instructions, operating procedures, and warranty. Put it and the original sales invoice in a safe, dry place for future reference.

TABLE OF CONTENTS

SECTION	PAGE
 SAFETY RULES	1
 ASSEMBLY	2
Unpacking Assembly Application	
 MAINTENANCE	4
General Maintenance	
 PARTS ILLUSTRATION & LIST	4
 WARRANTY	5

PRODUCT SPECIFICATIONS

Model No.	UT1002	
Top (with wood top)	A	25" x 14" (635 x 356 mm)
Leg Spacing	B	32" x 22-3/4" (813 x 578 mm)
Height (with wood top)	C	32-1/8" (816 mm)
Shelf		27" x 18" (686 x 457 mm)
Shelf height		16-1/4" (413 mm)
Weight		24 lbs (10.9 kg)

Figure 1

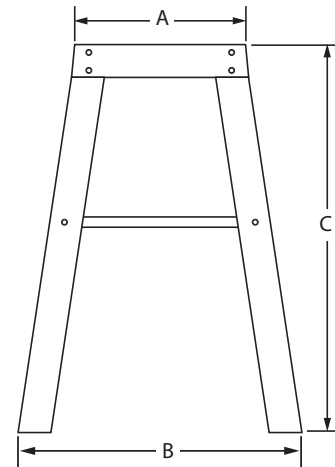
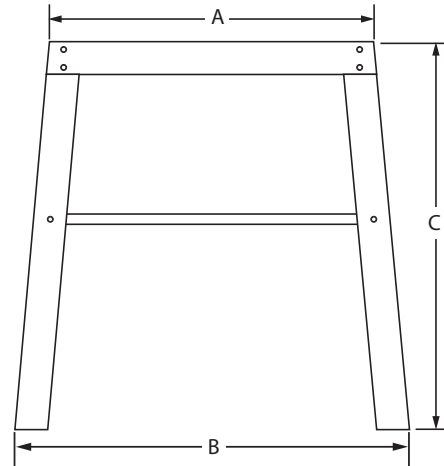

WARNING

- Do not use for scaffolding or as ladder. Do not stand or climb on the universal stand; it could tip over, causing serious injury.
- Do not overload. The maximum capacity for the universal stand is 500 lbs (227 kg).
- Do not apply an unbalanced load. This could cause the universal stand to tip over.
- Store the stand properly. Do not store the universal stand outdoors or in a damp location.
- Keep the work area clean, uncluttered, and well lit. Do not work on or place the universal stand legs on floor surfaces that are slippery from sawdust, oil, water or wax.
- Keep children and bystanders away while operating a power tool. Distractions may cause you to lose control. Visitors should wear the same safety equipment as the operator.
- When using a power tool with the universal stand, always follow the safety instructions in the power tool's operator's manual.
- Always wear safety glasses or eye shields when operating power tools.
- Dress properly. Do not wear loose clothing or jewelry. Keep your hair, clothing and gloves away from moving parts. Loose clothes, jewelry or long hair can be caught in moving parts. Always wear non-slip footwear. Tie back long hair. Roll long sleeves above the elbow.
- Always use clamps or other practical ways to support the work piece and secure it to a stable platform. Holding the work piece by hand or against your body is unstable and may lead to loss of control.

- Check all hardware prior to mounting any bench top tools.
- Inspect all hardware periodically and tighten any that may be loose.
- Be sure to use the proper mounting bolts for the unit being attached to the stand.

WARNING

For your own safety, read all of the rules and precautions before operating tool.

WARNING

Do not modify this tool and/or use it for any application other than that for which it was designed.

WARNING

Always follow proper operating procedures as defined in this manual even if you are familiar with use of this tool stand or any tool used with this stand. Remember that being careless for even a fraction of a second can result in severe personal injury.

You must be familiar with the use of any tool or accessory used with this stand. The supplier cannot be held responsible for any accident, injury or damage incurred while using this stand with any tool.

READ AND SAVE THESE INSTRUCTIONS

UNPACKING

Refer to Figure 2

Your new universal stand is shipped complete in one carton.

- Examine shipping carton for freight damage before opening. If shipping carton is damaged file a claim with the carrier immediately.
- Carefully unpack all loose items from the shipping carton and make sure all parts are accounted for.

ITEM	DESCRIPTION	QTY
A	Short upper cross brace	2
B	Shelf (two pieces)	2
C	Short lower cross brace	2
D	Long lower cross brace	2
E	Long upper cross brace	2
F	Leg	4
G	Feet	4
H	Table top (two pieces)	2
I	Pan head wood screw (table top)	10
J	Washer (table top)	12
K	Pan head screw (frame assembly)	24
L	Nut (frame assembly)	24
M	Pad (adjustable foot)	1
N	Countersink screw (adjustable foot)	1
O	Nut (adjustable foot)	2
P	Washer (adjustable foot)	1

Figure 2

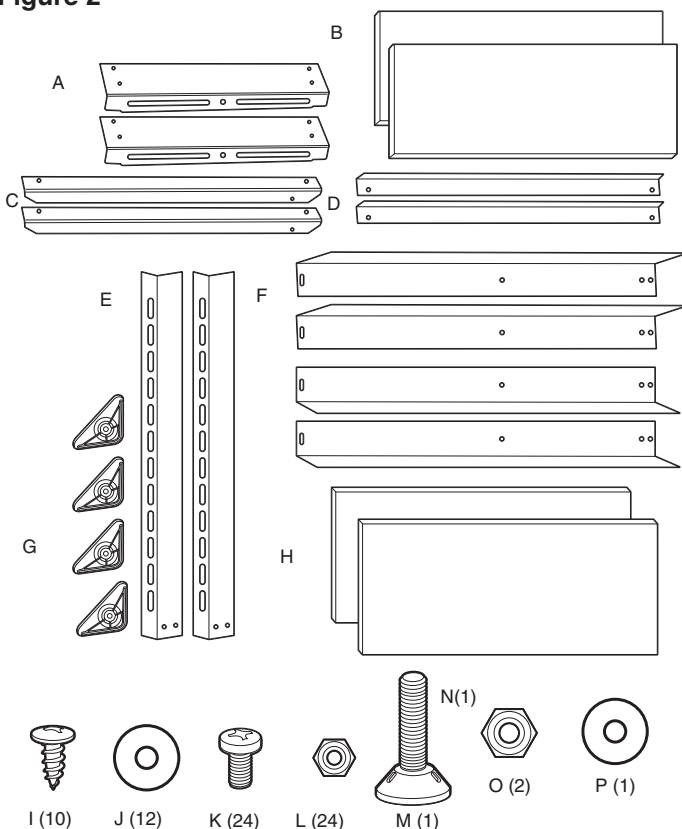

ASSEMBLY

Refer to Figure 3 - 5



Do not use this universal stand for scaffolding or as a ladder. Make sure to tighten all screws securely prior to use. Maximum capacity is 500 lbs (227 kg).

NOTE: Use pan head screws and nuts to assembly all components except the tabletop and leveling device.

NOTE: Do not fully tighten hardware until the stand is completely assembled. Always insert bolts from outside.

- Assemble one long upper cross brace to two legs using pan head screws and nuts.
- Assemble the long lower cross brace to the two legs. Make sure the long lower cross brace is positioned so the flange creates a ledge for the shelf.
- Repeat assembly on other two legs, long bottom and top braces.

Figure 3

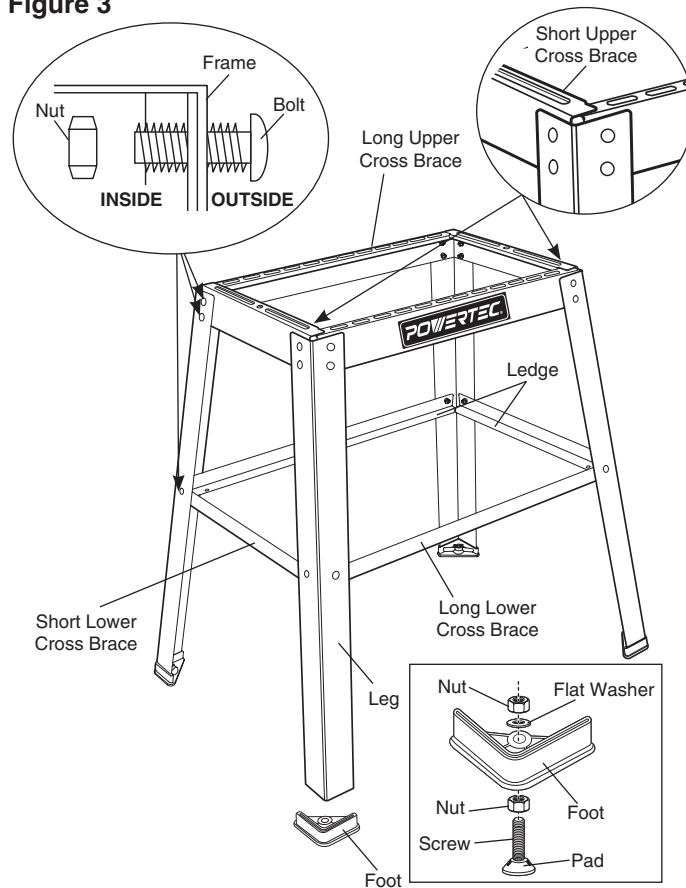

- Connect the four legs with the short top and bottom braces using carriage bolts and nuts. Make sure the short upper cross braces overlap the long upper cross braces as shown Figure 3 inset and the short lower cross braces are positioned so the flange creates a ledge for the shelf.
- Tighten all hardware.

- Hardware is supplied to make one of the feet adjustable. Insert the screw head into the pad, thread the nut onto the screw, now assemble the foot, flat washer and nut, Figure 3, inset.

NOTE: Adjust the foot by moving the nut on the screw up or down. If needed the feet can be interchanged to place the adjustable foot on any leg.

- Install feet to the bottom of the legs. Figure 3

NOTE: The table top will adjust from 14" to 20" for mounting larger bench tools. See **Table Top Adjustment** under **Applications**.

- Place the front and rear table top boards face down on a flat surface. Make sure the ruler printed on the table top is correct.
- Position the assembled frame onto the table top.
- Align the pre-drilled holes in the bottom of the table top with the slots in the top short braces. Attach the table top to the short upper cross braces using the eight wood screws and eight washers. Figure 4.

Figure 4

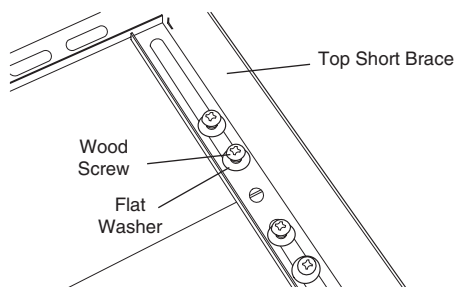

- Align the center pre-drilled holes in the table top with the slots in the long upper cross braces and secure with two wood screws and four washers. One additional washer is placed between the long upper cross brace and the table top.
- Turn the stand to the upright position.
- Slide the bottom shelves into place. Make sure they rest on the ledge. Figure 5

Figure 5

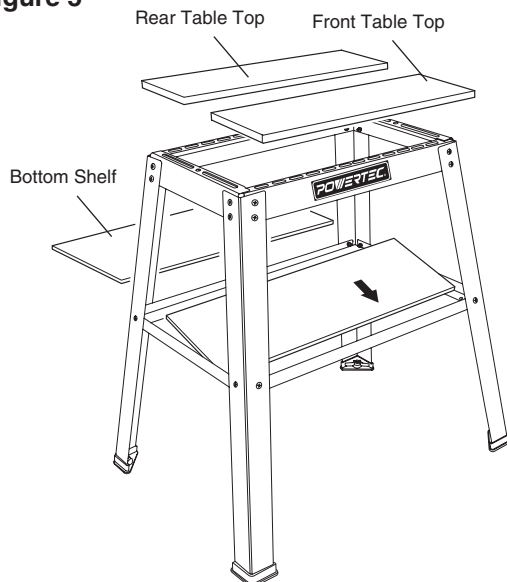

NOTE: Contact the customer service center if any of these parts are missing.

NOTE: After unit is assembled dispose of all packaging material in an environmentally safe way.

APPLICATIONS

WARNING

Do not use the universal stand for scaffolding or as a ladder. Make sure to securely tighten all fasteners before using. Maximum capacity is 500 lbs (227 kg). Power tools on the universal stand should not exceed a combined overall height of 60" (152.4 cm) from the floor.

When using the universal stand with a table saw, adjust the table top to the largest opening so debris does not accumulate.

Drill holes as needed into the table top. Mount all power tools with nuts and bolts (not supplied).

CAUTION

Be careful not to drill into the braces when drilling holes.

TABLE TOP ADJUSTMENT

Refer to Figure 6

NOTE: Assemble the table top in one of three positions. For a solid surface, place the edges of the table top boards together. For mounting larger bench tools adjust the table top to 14" or 20".

- Loosen the eight screws on the short upper cross braces. Remove the two screws and washers securing the center of the long upper cross braces to the stand.
- Slide the table top out and align the center of the long upper cross braces with the the pre-drilled holes at 14 or 20". Secure in place with the two wood screws and four washers. One additional washer is placed between the long upper cross brace and the table top.
- Tighten all of the fasteners.

Figure 6





GENERAL MAINTENANCE

⚠ WARNING

When servicing, use only identical replacement parts. Use of any other parts may create a hazard or cause product damage. To ensure safety and reliability, all repairs should be performed by a qualified service technician.

⚠ WARNING

Keep the universal stand dry, clean, and free from oil and grease. Always use a clean cloth when cleaning. Never use brake fluids, gasoline, petroleum based products or any strong solvent to clean the universal stand. Chemicals can damage, weaken or destroy plastic which may result in serious personal injury

4 UNIVERSAL STAND PARTS ILLUSTRATION & LIST

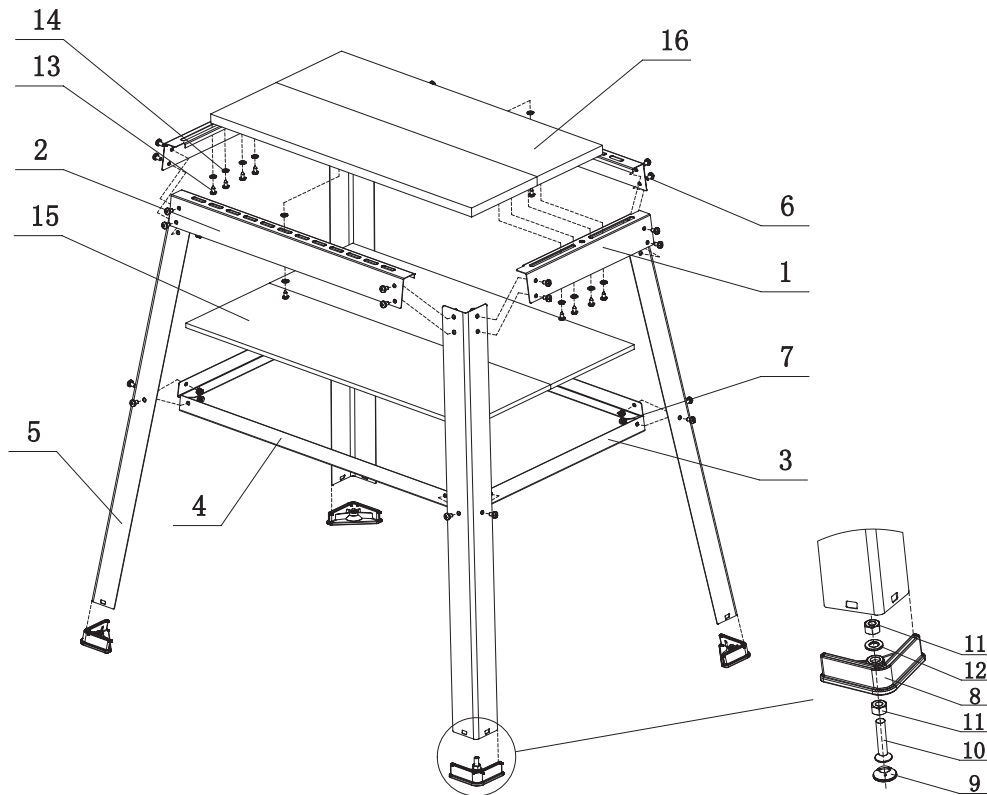

Key No.	Part No.	Description	Qty	Key No.	Part No.	Description	Qty
1	UT1002001	Short upper cross brace	2	9	UT1002009	Pad	1
2	UT1002002	Long upper cross brace	2	10	UT1002010	Countersink screw (M8*40)	1
3	UT1002003	Short lower cross brace	2	11	UT1002011	Nut (M8)	2
4	UT1002004	Long lower cross brace	2	12	UT1002012	Washer 8 mm	1
5	UT1002005	Leg	4	13	UT1002013	Pan head wood Nut (ST5.8x14)	10
6	UT1002006	Pan head screw (M6*10)	24	14	UT1002014	Washer 6 mm	12
7	UT1002007	Nut (M6)	24	15	UT1002015	Shelf (two pieces)	1
8	UT1002008	Feet	4	16	UT1002016	Tabletop (two pieces)	1

WARRANTY

1 5

Thank you for investing in a **POWERTEC** power tool. This product has been designed and manufactured to meet high quality standards and is guaranteed for domestic use against defects in workmanship or material for a period of 1 year from the date of purchase. This guarantee does not affect your statutory rights.

SOUTHERN TECHNOLOGIES LLC. BENCH TOP AND STATIONARY POWER TOOL LIMITED ONE YEAR WARRANTY AND 30-DAY SATISFACTION GUARANTEE POLICY

POWERTEC products are designed and manufactured by **Southern Technologies LLC**. All warranty communications should be directed to **Southern Technologies LLC**, 206 Terrace Dr. Mundelein, IL 60060, Attn: **POWERTEC** technical service; or by calling 1-877-393-7121 (toll free), 9 AM to 5 PM, Monday through Friday, US Central Time.

1
5

30- DAY SATISFACTION GUARANTEE POLICY

During the first 30 days after the date of purchase, if you are dissatisfied with the performance of this **POWERTEC** tool for any reason, you may return the tool to the retailer from which it was purchased for a full refund or exchange. You must present proof of purchase and return all original equipment packaged with the original product. The replacement tool will be covered by the limited warranty for the balance of the one year warranty period.

LIMITED ONE YEAR WARRANTY

This warranty covers all defects in workmanship or materials in this **POWERTEC** tool for a one year period from the date of purchase. This warranty is specific to this tool. **Southern Technologies, LLC** reserves the right to repair or replace the defective tool, at its discretion.

HOW TO OBTAIN SERVICE

To obtain service for this **POWERTEC** tool you must return it, freight prepaid, to **POWERTEC**. You may call (toll free) 1-877-393-7121 for more information. When requesting warranty service, you must present the proof of purchase documentation, which includes a date of purchase. **POWERTEC** will either repair or replace any defective part, at our option at no charge to you. The repaired or replacement unit will be covered by the same limited warranty for the balance of one year warranty period.

WHAT IS NOT COVERED

This warranty applies to the original purchaser at retailer and may not be transferred.

This warranty does not cover consumable items such as saw blades, knives, belts, discs, cooling blocks and sleeves. This warranty does not cover required service and part replacement resulting from normal wear and tear, including accessory wear.

This warranty does not cover any malfunction, failure or defect resulting from:

- 1) misuse, abuse, neglect and mishandling not in accordance with the owner's manual.
- 2) damage due to accidents, natural disasters, power outage, or power overload.
- 3) commercial or rental use.
- 4) alteration, modification or repair performed by persons not recommended by **POWERTEC**.

DISCLAIMER

To the extent permitted by applicable law, all implied warranties, including warranties of MERCHANTABILITY or FITNESS FOR A PARTICULAR PURPOSE, are disclaimed. Any implied warranties, that cannot be disclaimed under state law are limited to one year from the date of purchase. **Southern Technologies LLC**, is not responsible for direct, indirect, incidental or consequential damages. Some states do not allow limitations on how long an implied warranty lasts and/or do not allow the exclusion or limitation of incidental or consequential damages, so the above limitations may not apply to you. This warranty gives you specific legal rights, and you may also have other rights which vary from state to state. **Southern Technologies LLC**, makes no warranties, representations, or promises as to the quality or performance of its power tools other than those specifically stated in this warranty.

POWERTEC[®]

Southern Technologies, LLC
206 Terrace Drive
Mundelein, Illinois 60060