

Owner's Manual

POWERTEC[®]

Wall Mount Dust Collector

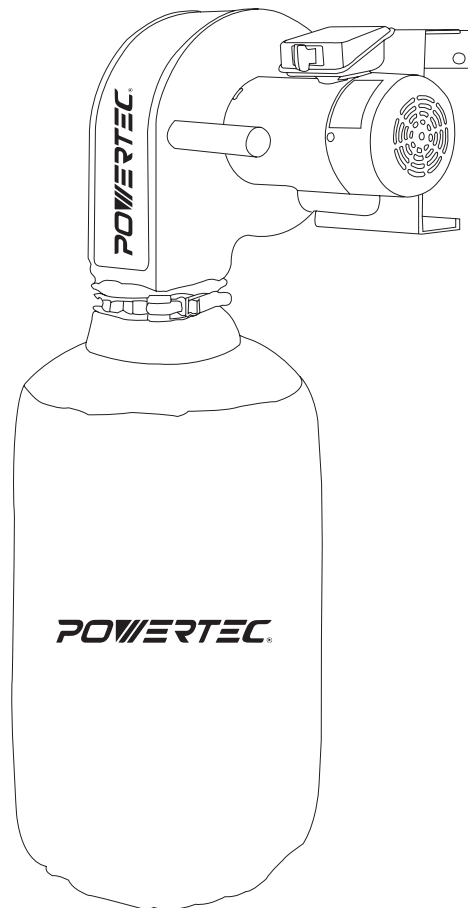







Visit us on the web at www.powertecproducts.com



You will need this manual for safety instructions, operating procedures, and warranty. Put it and the original sales invoice in a safe, dry place for future reference.

TABLE OF CONTENTS

SECTION	PAGE
 SAFETY RULES	1
Work Preparation Work Area Preparation Tool Maintenance Tool Operation	
 ASSEMBLY	2
Unpacking Installation Test Power Source Grounding Instructions Extension Cords Motor Electrical Connections	
 OPERATION	5
Basic Operations	
 MAINTENANCE	6
General Maintenance Cleaning Lubrication Machine Storage Tool Repairs	
 TROUBLESHOOTING	7
 PARTS ILLUSTRATION & LIST	8
 WARRANTY	9

PRODUCT SPECIFICATIONS

Motor	1-HP, 120/240 V, 60-Hz, 1PH
Motor Speed	3450 RPM
Bearings	Sealed & Permanently Lubricated
Cord Length	6 Feet
Air Suction Capacity	537 CFM
Max. Static Pressure	7.2" (182.8 mm)
Main Inlet Size	4" (101.6 mm)
Impeller Type	Radial Fin
Impeller Size	10" (254 mm)
Collection Bag (with a clear window and bottom zipper)	2.5 micron
Overall Dimensions	20" x 18" x 45" (508 x 457 x 1143 mm)
Weight	52 lbs (23.6 kg)

SAFETY RULES



1

WARNING

For your own safety, read and understand all warnings and operating instructions before using any tool or equipment.

WARNING

Some dust created by power sanding, sawing, grinding, drilling and other construction activities contains chemicals known to the State of California to cause cancer, birth defects or other reproductive harm.

Some examples of these chemicals are:

- Lead from lead-based paints.
- Crystalline silica from bricks and cement and other masonry products.
- Arsenic and chromium from chemically-treated lumber.

Your risk from these exposures varies, depending on how often you do this type of work. To reduce your exposure to these chemicals: work in a well ventilated area and work with approved safety equipment. Always wear OSHA/NIOSH approved, properly fitting face mask or respirator when using such tools.

WARNING

Always follow proper operating procedures as defined in this manual even if you are familiar with the use of this or similar tools. Remember that being careless for even a fraction of a second can result in severe personal injury.

WORK PREPARATION

- Wear proper apparel. Do not wear loose clothing, gloves, neckties, rings, bracelets or other jewelry which may get caught in moving parts of the tool.
- Wear protective hair covering to contain long hair.
- Wear safety shoes with non-slip soles.
- Wear safety glasses complying with United States ANSI Z87.1. Everyday glasses have only impact resistant lenses. They are NOT safety glasses.
- Wear face mask or dust mask if operation is dusty.
- Be alert and think clearly. Never operate power tools when tired, intoxicated or when taking medications that cause drowsiness.

WORK AREA PREPARATION

- Keep work area clean. Cluttered work areas invite accidents.
- Do not use power tools in dangerous environments. Do not use power tools in damp or wet locations. Do not expose power tools to rain.
- Work area should be properly lit.
- Proper electrical receptacle should be available for tool. Three-prong plug should be plugged directly into properly grounded, three-prong receptacle.
- Extension cords should have a grounding prong and the three wires of the extension cord should be of the correct gauge.
- Keep visitors at a safe distance from work area.

- Keep children out of the work area. Ensure your work shop is child-proof. Use padlocks, master switches or remove switch keys to prevent any unintentional use of power tools.

TOOL MAINTENANCE

- Always unplug tool prior to inspection.
- Consult manual for specific maintaining and adjusting procedures.
- Keep tool lubricated and clean for a safe operation.
- Remove adjusting tools. Form habit of checking to see adjusting tools or accessories are removed before switching tool on.
- Keep all parts in working order. Check to determine that guard or other parts will operate properly and perform their intended function.
- Check for damaged parts. Check for alignment of moving parts, binding, breakage, mounting and any other condition that may affect tool's operation.
- A guard or any other part that is damaged should be properly repaired or replaced. Do not perform makeshift repairs.

TOOL OPERATION

- Use the right tool for your job. Do not force your tool or attachment to do a job for which it was not designed.
- Avoid accidental start-up. Make sure that the tool is in the "OFF" position before plugging in.
- Never leave tool running unattended.
- Know your tool. Learn the tool's operation, application and specific limitations before using it.

CAUTION

Think safety! Safety is a combination of operator common sense and alertness at all times when tool is being used.

WARNING

Do not attempt to operate tool until it is completely assembled according to the instructions.

SAVE ALL WARNINGS AND INSTRUCTIONS FOR FUTURE REFERENCE



1

2

SPECIFIC SAFETY INSTRUCTIONS

WARNING

Read and understand the instruction manual before operating the dust collector. Basic precautions listed below should always be followed when using your dust collector to reduce the risk of injury, electrical shock or fire.

- This dust collector is designed to collect sawdust only.
- Never attempt to use this dust collector to vacuum water or any other liquids.
- Never try to use this dust collector to collect large wood pieces.
- Never attempt to use this dust collector to collect metal materials such as screws, nails or other metal parts.
- Always wear approved eye protection and respirator when emptying collection/filter bags.

- Never operate the dust collector with all blast gates closed.
- Turn machine off, disconnect power cord and ensure all moving parts have stopped completely before changing or emptying the bags.
- ALWAYS ensure collection/filter bags are secured in place.
- Do not place your hand or tools near the open inlet while operating. Serious personal injury or damage to the machine can happen.
- Always connect dust collector to the matched power source.

IMPORTANT : Always consider safety first as it applies to your individual working conditions, the environment in every shop is different.

SAVE ALL WARNINGS AND INSTRUCTIONS FOR FUTURE REFERENCE

2

ASSEMBLY

UNPACKING

Refer to Figure 1.

Check for shipping damage. Check immediately whether all parts and accessories are included. If anything is missing or broken, contact your retailer or call **847-780-6120**.

- Carefully remove all contents from shipping carton. The shipping carton contains:

ITEM	DESCRIPTION	QUANTITY
A	Motor Housing	1
B	Dust Collection Bag	1
C	Motor Bracket	1
D	Wall Mounting Bracket	1
E	Quick Release Bag Clamp	1
F	Foam Strip	1
G	Hardware Bag (contains four flange bolts)	1
H	12-10 mm Wrench	1
	Owner's Manual (not shown)	

Figure 1

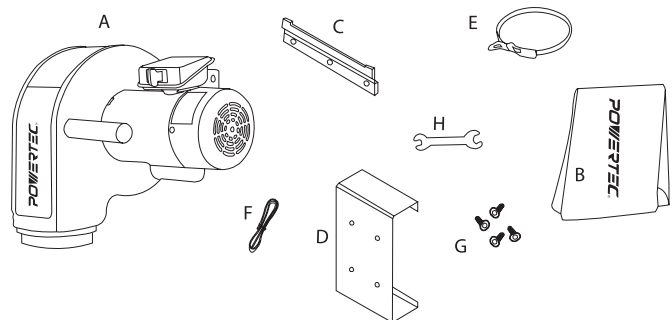
**INSTALLATION**

Refer to Figures 2 - 3

CAUTION

Do not attempt assembly if parts are missing. Call the Customer service line to obtain replacement parts.

WARNING

Do not operate dust collector until completely assembled. Do not operate this tool until you have completely read and understood this manual.

NOTE: After unit is assembled dispose of all packaging material in an environmentally safe way.

Tools required for assembly:

- 10 mm Wrench
1. Align holes in motor bracket with holes in motor housing, secure bracket in place with four bolts supplied.

Figure 2

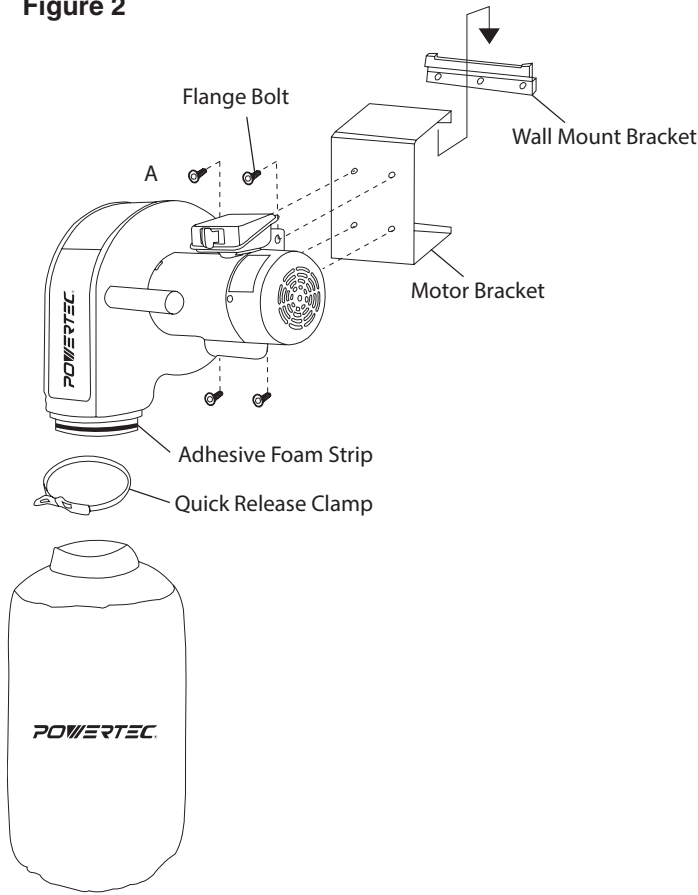

2. Wall mounting bracket placement:

NOTE: The mounting bracket must be placed a minimum of 44" (1117.6 mm) from the floor and a minimum of 6" (152.4 mm) from the corner or adjoining wall so the motor has sufficient cooling space.

NOTE: Place the mounting bracket near an existing power source. Make sure all power cords will be protected from traffic, material handling, moisture, chemicals or other hazards. Ensure the power source is easy to access.

Figure 3

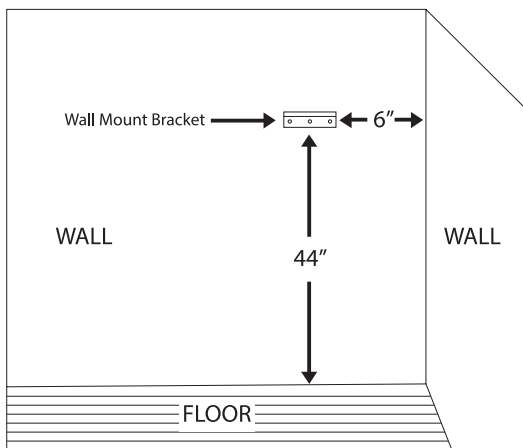

3. Use the wall mounting bracket as a template to mark mounting holes.

- If mounting on a masonry wall use lag screws with lag shield anchor studs (not supplied).

- If mounting to a framed wall attach the mounting bracket to a support board. Attach the support board with lag screws (not supplied).
4. Hang the dust collector onto the wall mounting bracket.
 5. Place the adhesive foam strip (supplied) around the dust collector outlet port.
 6. Place the dust collector bag onto the outlet port and secure in place with the quick release bag clamp (supplied).

TEST



Before starting the dust collector, make sure you have read and understood the manual and you are familiar with the functions and safety features on the machine. Failure to do so may cause serious personal injury.

Run a test to ensure the dust collector operates properly.

1. Ensure all tools are removed from the work area and the wall mounting bracket is secure.
2. Plug the power cord into the correct receptacle. (Refer to **Power Source** paragraph in this section of the manual.)
3. Turn the dust collector ON. (Refer to **On/Off Switch** paragraph in **Operation** section of the manual.)
4. If unusual noise or excessive vibration is noticed, shut off the machine immediately and disconnect the cord from the power source. Check all the assembled parts once again and investigate to find the problem.
5. If the dust collector operates correctly, turn the machine OFF and remove the safety key on the switch. Once the safety key is removed, turn the switch ON. The machine should not run with the safety key removed.

If everything operates correctly the dust collector is ready for use.

POWER SOURCE



Do not connect dust collector to the power source until all assembly steps have been completed.

The motor is designed for operation on the voltage and frequency specified. Normal loads will be handled safely on voltages not more than 10% above or below specified voltage. Running the unit on voltages which are not within the range may cause overheating and motor burn-out. Heavy loads require that the voltage at motor terminals be no less than the voltage specified on nameplate.

- Power supply to the motor is controlled by a single pole locking rocker switch. Remove the key to prevent unauthorized use.

GROUNDING INSTRUCTIONS

⚠ WARNING

Improper connection of equipment grounding conductor can result in the risk of electrical shock. Equipment should be grounded while in use to protect operator from electrical shock.

- Check with a qualified electrician if you do not understand grounding instructions or if you are in doubt as to whether the tool is properly grounded.
- This tool is equipped with an approved cord rated at 120V and a 3-prong grounding type plug (see Figure 4) for your protection against shock hazards.
- Grounding plug should be plugged directly into a properly installed and grounded 3-prong grounding type receptacle, as shown (see Figure 4).

Figure 4

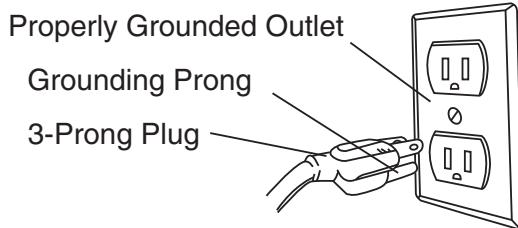

- Do not remove or alter grounding prong in any manner. In the event of a malfunction or breakdown, grounding provides a path of least resistance for electrical shock.

⚠ WARNING

Do not allow fingers to touch the terminals of plug when installing or removing from outlet.

- Plug must be plugged into matching outlet that is properly installed and grounded in accordance with all local codes and ordinances. Do not modify plug provided. If it will not fit in outlet, have proper outlet installed by a qualified electrician.
- Inspect tool cords periodically, and if damaged, have repaired by an authorized service facility.
- Green (or green and yellow) conductor in cord is the grounding wire. If repair or replacement of the electric cord or plug is necessary, do not connect the green (or green and yellow) wire to a live terminal.

EXTENSION CORDS

- The use of an extension cord is not recommended. The use of any extension cord will cause some drop in voltage and loss of power.
- Wires of the extension cord must be of sufficient size to carry the current and maintain adequate voltage.
- Use the table to determine the minimum wire size (A.W.G.) extension cord.
- Use only 3-wire extension cords having 3-prong grounding type plugs and 3-pole receptacles which accept the tool plug.
- If the extension cord is worn, cut or damaged in any way, replace it immediately.

Extension Cord Length

Wire Size.....	A.W.G.
Up to 50 ft.....	14 gauge

NOTE: Using extension cords over 50 ft. long is not recommended.

MOTOR

The dust collector is assembled with motor and wiring installed. The electrical wiring schematic is shown in Figure 5.

The permanently split capacitor motor has the following specifications:

Horsepower (Peak HP).....	1
Voltage	120/240
Amp	7/3.5
Hertz	60
Phase	Single
RPM.....	3450

ELECTRICAL CONNECTIONS

⚠ WARNING

All electrical connections must be performed by a qualified electrician. Make sure tool is off and disconnected from power source while motor is mounted, connected, reconnected or anytime wiring is inspected. Motor and wires are installed as shown in wiring schematic (See Figure 5). Motor is assembled with approved, 3-conductor cord to be used at 120 volts.

Figure 5

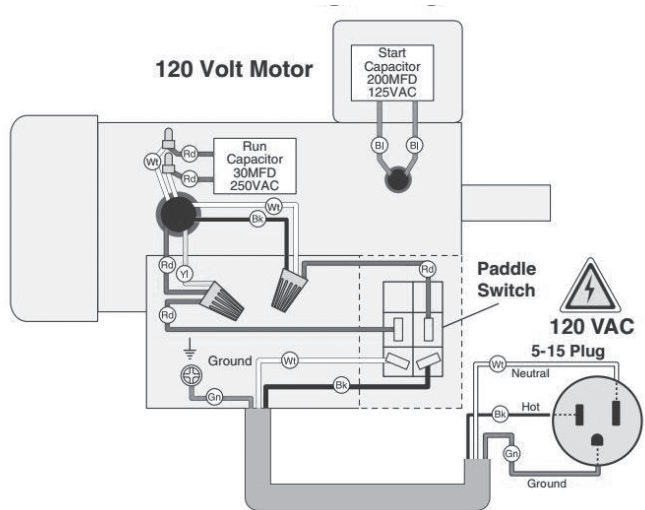

The power lines are inserted directly into the switch. The green ground line must remain securely fastened to the frame to properly protect against electrical shock. The power supply to the motor is controlled by a single pole locking rocker switch.

- Remove the key to prevent unauthorized use.



BASIC OPERATIONS

ON/OFF Switch

The keyed switch is intended to prevent unauthorized use of the dust collector.

1. To turn the dust collector ON insert the yellow key into the key slot in the center of the switch.
2. Push the key firmly into the slot, then push switch to the ON position to start the dust collector.
3. To turn the dust collector OFF push the switch to the down position.
4. Remove the yellow switch key, when the dust collector has come to a complete stop, by gently pulling it outward.

WARNING

Remove the switch key whenever the dust collector is not in use.

Place it in a safe place and out of reach of children.

WARNING

ALWAYS lock the switch OFF when the dust collector is not in use. Remove the key and keep it in a safe place. In the event of power failure, blown fuse, or tripped circuit breaker, turn the switch OFF and remove the key, preventing accidental startup when power comes on.

Figure 6

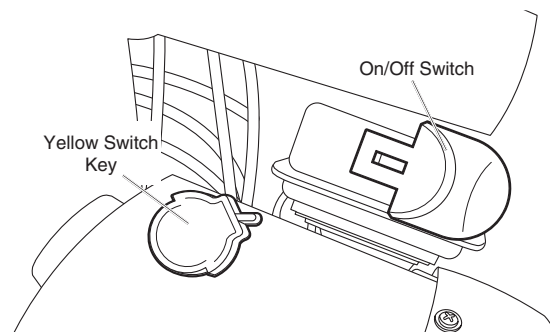

Operation

1. Position the tool being used close to the dust collector.
2. Connect one end of a dust collector hose to the dust collector inlet and one end to the machine outlet. Secure both ends with hose clamps (not included).
3. Turn the dust collector ON. (Refer to **On/Off Switch** paragraph in this section of the manual.)

Figure 7

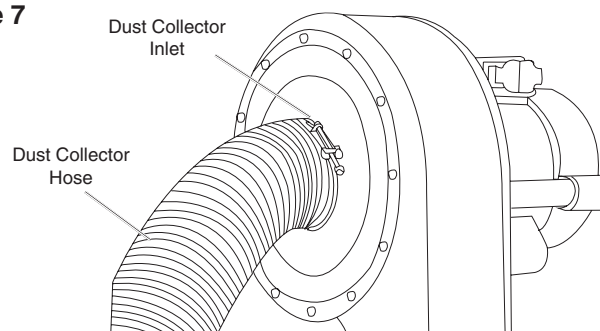



GENERAL MAINTENANCE

WARNING

Make sure the machine is turned off and the cord is disconnected from the power source before servicing and removing/replacing any components on the machine.

- Check the dust collector daily for loose mounting bolts, screws, damaged wires, worn switch, full collection bag and any other unsafe condition.
- The impeller screw may loosen with use. Check the impeller once a month to ensure the impeller screws are tight, securing the impeller on the shaft.

To check: Make sure the machine is turned off and the cord is disconnected from the power source. Access the impeller screws through the inlet cover on the machine and tighten to secure the impeller on the shaft.

CLEANING

Check and empty the collection bag on your dust collector regularly. The machine operates at a much higher level of efficiency when the collection bag is empty.

This collection bag has a clear window and a bottom zip. The clear window allows operator to see the amount of dust in the bag and the bottom zip makes bag emptying easy.

LUBRICATION

The sealed bearings in the motor have been permanently lubricated at the factory. They require no further lubrication.

MACHINE STORAGE

- When the dust collector is not in use, disconnect the cord from the power source and store the machine in a dry place.
- Do not expose the machine to rain.
- Ensure the cord is kept away from potential damage sources such as; sharp objects, chemicals, heat sources and water.

TOOL REPAIRS

- If power cord is worn, cut, or damaged in any way, have it replaced immediately.
- Replace worn abrasives when needed.
- Replace any damaged or missing parts. Use parts list to order parts. Any attempt to repair motor may create a hazard unless repair is done by a qualified service technician. Call the customer service line at **847-780-6120** for assistance.





SYMPTOM	POSSIBLE CAUSE(S)	CORRECTIVE ACTION
Motor will not start	<ol style="list-style-type: none"> 1. Low voltage 2. Open circuit in motor or loose connections 3. Defective switch 4. Defective capacitor 5. Switch key is removed 	<ol style="list-style-type: none"> 1. Check power line for proper voltage 2. Inspect all lead connections on motor for loose or open connection 3. Replace switch 4. Replace capacitor 5. Insert switch key
Motor will not start; fuses blown or circuit breakers are tripped	<ol style="list-style-type: none"> 1. Short circuit in line cord or plug 2. Short circuit in motor or loose connections 3. Incorrect fuses or circuit breakers in power line 	<ol style="list-style-type: none"> 1. Inspect line cord or plug for damaged insulation and shorted wires 2. Inspect all lead connections on motor for loose or shorted terminals or worn insulation on wires 3. Install correct fuses or circuit breakers
Unit has vibration or noisy operation	<ol style="list-style-type: none"> 1. Motor or components are loose 2. Motor mount is loose/broken 3. Unit is incorrectly mounted to wall 4. Motor fan is rubbing cover 5. Motor bearings faulty 	<ol style="list-style-type: none"> 1. Inspect/replace any stripped or damaged bolts/nuts and re-tighten. 2. Tighten/replace 3. Tighten/replace mounting hardware 4. Replace fan cover; replace loose/damaged fan 5. Call the customer service line at 847-780-6120 for assistance
Loud, repetitious noise or excessive vibration coming from dust collector	<ol style="list-style-type: none"> 1. Dust collection bag is full 2. Dust collector hose restricted 3. The lumber is wet and dust is not flowing through the hose smoothly 4. There is a leak in the hose 	<ol style="list-style-type: none"> 1. Empty collection bag. 2. Remove hose from dust collector inlet and unblock the restriction in the hose. A plumbing snake may be necessary. 3. Process lumber with less than 20% moisture content. 4. Inspect and replace hose.
Sawdust blown into the air from the dust collector	Hose clamps or dust collection bag is not properly clamped and secured.	Check hose and dust collection bag, ensure hose and bag clamps are tight and completely over the hose and bag.

8 WALL MOUNT DUST COLLECTOR PARTS ILLUSTRATION

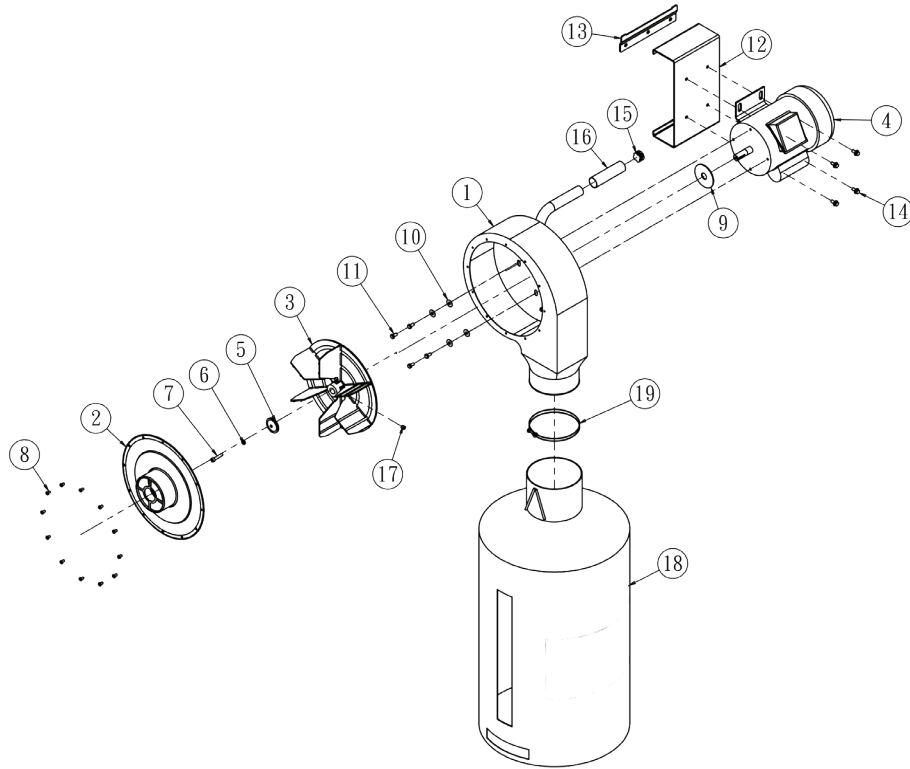

WALL MOUNT DUST COLLECTOR PARTS LIST

Key No.	Part No	Description	Qty
1	DC5370001	Main housing	1
2	DC5370002	Inlet cover 4"	1
3	DC5370003	Impeller 10"	1
4	DC5370004	Motor	1
5	DC5370005	Impeller washer	1
6	DC5370006	Spring washer 1/4"	1
7	DC5370007	Cap screw M6 x 30	1
8	DC5370008	Phillip HD tp screw M5 x10	12
9	DC5370009	Motor gasket	1
10	DC5370010	Flat washer 1/4" x 18	4
11	DC5370011	Hex screw 1/4" x 1/2"	4
12	DC5370012	Motor plate	1
13	DC5370013	Wall mount bracket	1
14	DC5370014	Flange bolt 1/4" x 1/2"	4
15	DC5370015	Cap 1"	1
16	DC5370016	Handle cover	1
17	DC5370017	Set screw 5/16" x 5/16"	1
18	DC5370018	Collection bag	1
19	DC5370019	Bag clamp 5"	1

Thank you for investing in a **POWERTEC** power tool. This product has been designed and manufactured to meet high quality standards and is guaranteed for domestic use against defects in workmanship or material for a period of 12 months from the date of purchase. This guarantee does not affect your statutory rights.

SOUTHERN TECHNOLOGIES LLC. BENCH TOP AND STATIONARY POWER TOOL LIMITED 1 YEAR WARRANTY AND 30-DAY SATISFACTION GUARANTEE POLICY

POWERTEC products are designed and manufactured by **Southern Technologies LLC**. All warranty communications should be directed to **Southern Technologies LLC** by calling 847-780-6120 (toll free), 9 AM to 5 PM, Monday through Friday, US Central Time.



30- DAY SATISFACTION GUARANTEE POLICY

During the first 30 days after the date of purchase, if you are dissatisfied with the performance of this **POWERTEC** tool for any reason, you may return the tool to the retailer from which it was purchased for a full refund or exchange. You must present proof of purchase and return all original equipment packaged with the original product. The replacement tool will be covered by the limited warranty for the balance of the one year warranty period.

LIMITED ONE YEAR WARRANTY

This warranty covers all defects in workmanship or materials in this **POWERTEC** tool for a one year period from the date of purchase. This warranty is specific to this tool. **Southern Technologies, LLC** reserves the right to repair or replace the defective tool, at its discretion.

HOW TO OBTAIN SERVICE

To obtain service for this **POWERTEC** tool you must return it, freight prepaid, to **POWERTEC**. You may call (toll free) 847-780-6120 for more information. When requesting warranty service, you must present the proof of purchase documentation, which includes a date of purchase. **POWERTEC** will either repair or replace any defective part, at our option at no charge to you. The repaired or replacement unit will be covered by the same limited warranty for the balance of one year warranty period.

WHAT IS NOT COVERED

This warranty applies to the original purchaser at retailer and may not be transferred.

This warranty does not cover consumable items such as saw blades, knives, belts, discs, cooling blocks and sleeves. This warranty does not cover required service and part replacement resulting from normal wear and tear, including accessory wear.

This warranty does not cover any malfunction, failure or defect resulting from:

- 1) misuse, abuse, neglect and mishandling not in accordance with the owner's manual.
- 2) damage due to accidents, natural disasters, power outage, or power overload.
- 3) commercial or rental use.
- 4) alteration, modification or repair performed by persons not recommended by **POWERTEC**.

DISCLAIMER

To the extent permitted by applicable law, all implied warranties, including warranties of **MERCHANTABILITY** or **FITNESS FOR A PARTICULAR PURPOSE**, are disclaimed. Any implied warranties, that cannot be disclaimed under state law are limited to one year from the date of purchase. **Southern Technologies LLC**, is not responsible for direct, indirect, incidental or consequential damages. Some states do not allow limitations on how long an implied warranty lasts and/or do not allow the exclusion or limitation of incidental or consequential damages, so the above limitations may not apply to you. This warranty gives you specific legal rights, and you may also have other rights which vary from state to state. **Southern Technologies LLC**, makes no warranties, representations, or promises as to the quality or performance of its power tools other than those specifically stated in this warranty.

POWERTEC[®]

Southern Technologies, LLC
Waukegan, IL 60087