

# Owner's Manual

# POWERTEC®

## 6" Heavy Duty Bench Buffer

**?** QUESTION...  
1•847•780•6120

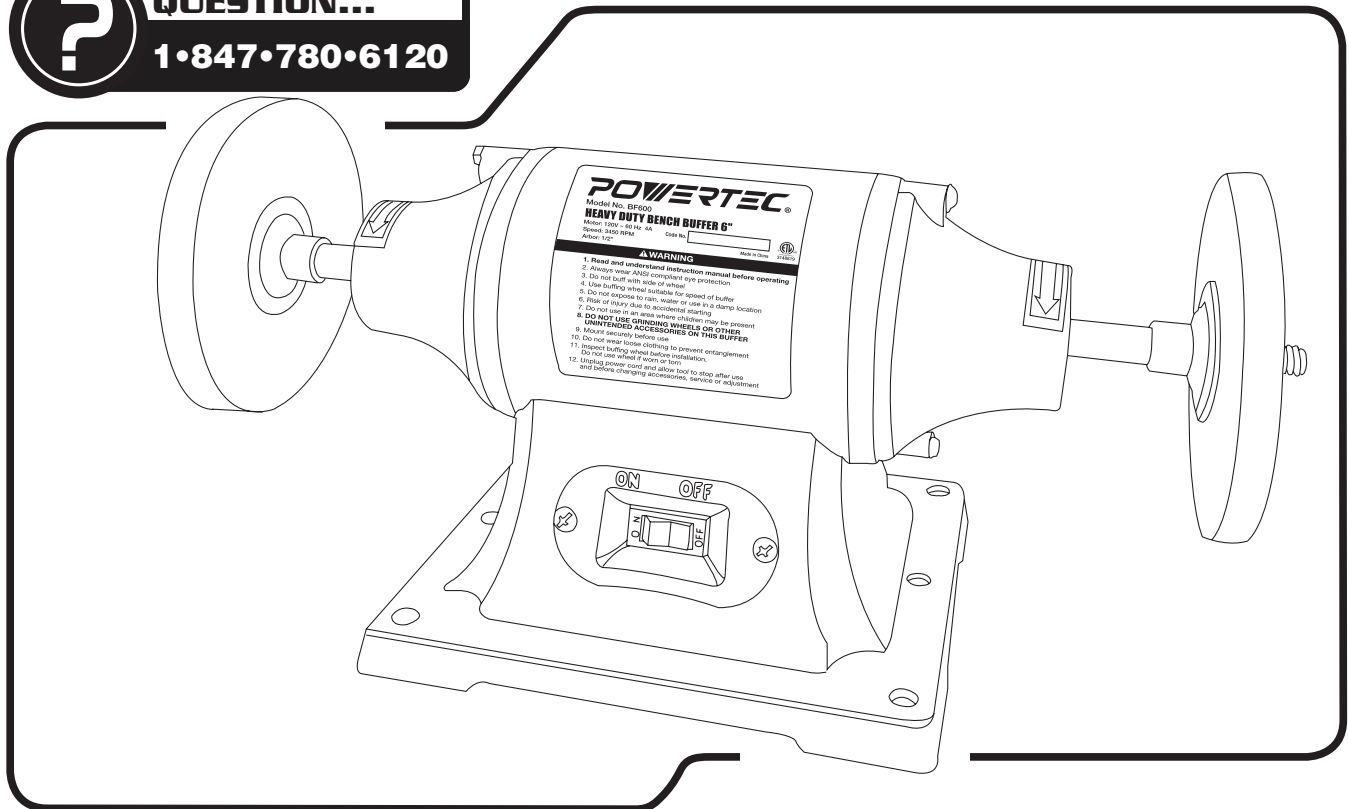









Visit us on the web at [powertecproducts.com](http://powertecproducts.com)



You will need this manual for safety instructions, operating procedures, and warranty. Put it and the original sales invoice in a safe, dry place for future reference.

# TABLE OF CONTENTS

SECTION	PAGE
 <b>SAFETY RULES</b>	<b>1</b>
Work Preparation Work Area Preparation Tool Maintenance Tool Operation	
 <b>SPECIFIC SAFETY RULES</b>	<b>2</b>
 <b>ASSEMBLY</b>	<b>3</b>
Unpacking Tools Needed Set Up Power Source Grounding Instructions Extension Cords	
 <b>OPERATION</b>	<b>5</b>
Basic Operation	
 <b>MAINTENANCE</b>	<b>5</b>
General Maintenance Cleaning	
 <b>TROUBLESHOOTING</b>	<b>6</b>
 <b>PARTS ILLUSTRATION &amp; LIST</b>	<b>8</b>
 <b>WARRANTY</b>	<b>10</b>

# PRODUCT SPECIFICATIONS

Electrical Rating . . . . . 120VAC / 60Hz / 4A  
Motor No Load Speed . . . . . 3450 RPM  
Max. Accessory Diameter . . . . . 6" (152.4 mm)  
Arbor Size . . . . . 1/2" (12.7 mm)

# SAFETY RULES



1

## WARNING

For your own safety, read and understand all warnings and operating instructions before using any tool or equipment.

## WARNING

Some dust created by operation of power tool contains chemicals known to the State of California to cause cancer, birth defects or other reproductive harm. To reduce your exposure to these chemicals, work in a well ventilated area and work with approved safety equipment. Always wear OSHA/NIOSH approved, properly fitting face mask or respirator when using such tools.

## WARNING

Failure to follow these rules may result in serious personal injury. Remember that being careless for even a fraction of a second can result in severe personal injury.

## WORK PREPARATION

- Wear proper apparel. Do not wear loose clothing, gloves, neckties, rings, bracelets or other jewelry which may get caught in moving parts of the tool.
- Nonslip protective footwear is recommended. Wear protective hair covering to contain long hair.
- Wear eye and hearing protection. Always use safety glasses. Eye protection equipment should comply with ANSI Z87.1 standards. Hearing equipment should comply with ANSI S3.19 standards.
- Wear face mask or dust mask if operation is dusty.
- Be alert and think clearly. Never operate power tools when tired, intoxicated or when taking medications that cause drowsiness.

## WORK AREA PREPARATION

- Keep work area clean. Cluttered work areas and benches invite accidents.
- Work area should be properly lit.
- Do not use the machine in a dangerous environment. The use of power tools in damp or wet locations or in rain can cause shock or electrocution.
- Three-prong plug should be plugged directly into properly grounded, three-prong receptacle.
- Use the proper extension cord. Make sure your extension cord is in good condition. It should have grounding prong and should be of the correct gauge.
- Keep children and visitors away. Your shop is a potentially dangerous environment. Children and visitors can be injured.
- Make your workshop childproof with padlocks, master switches or remove switch keys to prevent any unintentional use of power tools.

## TOOL MAINTENANCE

- Turn the machine "OFF", and disconnect the machine from the power source prior to inspection.
- Maintain all tools and machines in peak condition. Keep tools sharp and clean for best and safest performance.
- Follow instructions for lubricating and changing accessories.
- Check for damaged parts. Check for alignment of moving parts, binding, breakage, mounting and any other condition that may affect tool's operation.
- Poorly maintained tools and machines can further damage the tool or machine and/or cause injury.
- A guard or any other part that is damaged should be repaired or replaced. Do not perform makeshift repairs.

## TOOL OPERATION

- Avoid accidental start-up. Make sure that the tool is in the "OFF" position before plugging in.
- Use the right tool for your job. Do not force your tool or attachment to do a job for which it was not designed.
- Disconnect tool when changing parts.
- Don't force the workpiece on the machine. Damage to the machine and/or injury may result.
- Never leave tool running unattended. Turn the power off and do not leave tool until it comes to a complete stop.
- Do not overreach. Loss of balance can make you fall into a working machine, causing injury.
- Never stand on tool. Injury could occur if the tool tips, or if you accidentally contact the cutting tool.
- Know your tool. Learn the tool's operation, application and specific limitations before using it.
- Use a proper extension cord of the correct gauge. Your extension cord should have a grounding prong, and should be in good condition.
- Handle workpiece correctly. Keep hands away from moving parts.
- Turn tool off if it jams.
- Always feed workpiece against the direction of the sanding rotation. To maintain control, properly support long or wide work-pieces.

## CAUTION

Think safety! Safety is a combination of operator common sense and alertness at all times when tool is being used.

## WARNING

Do not attempt to operate tool until it is completely assembled according to the instructions.

**SAVE ALL WARNINGS AND INSTRUCTIONS  
FOR FUTURE REFERENCE**



1



2



## SPECIFIC SAFETY RULES FOR BENCH BUFFER

Be aware of general power tool safety. Make sure all the safety rules are understood.

- Wear eye protection.
- Use buffing wheel suitable for speed of bench buffer.
- Do not buff with side of wheel.
- DO NOT use grinding wheels or other unintended accessories on this bench buffer.
- DO NOT operate with any guard disabled, damaged or removed.
- The use of accessories or attachments not recommended by the manufacturer may result in a risk of injury to persons.
- When servicing use only identical replacement parts.
- Only use safety equipment that has been approved by an appropriate standards agency. Unapproved safety equipment may not provide adequate protection. Eye protection must be ANSI-approved and breathing protection must be NIOSH-approved for the specific hazards in the work area.
- Stay alert, watch what you are doing and use common sense when operating a power tool.
- Do not use a power tool while you are tired or under the influence of drugs, alcohol or medication. A moment of inattention while operating power tools may result in serious personal injury.
- Industrial applications must follow OSHA guidelines
- Maintain labels and nameplates on the tool. These carry important safety information.
- Avoid unintentional starting. Prepare to begin work before turning on the tool.
- People with pacemakers should consult their physician(s) before use. Electromagnetic fields in close proximity to heart pacemaker could cause pacemaker interference or pacemaker failure.

### **WARNING**

**Handling the cord on this product will expose you to lead, a chemical known to the State of California to cause cancer, and birth defects or other reproductive harm. Wash hands after handling. (California Health & Safety Code § 25249.5, et seq.)**

- The warnings, precautions, and instructions discussed in this instruction manual cannot cover all possible conditions and situations that may occur.
- It must be understood by the operator that common sense and caution are factors which cannot be built into this product, but must be supplied by the operator.

### Vibration Safety

This tool vibrates during use. Repeated or long-term exposure to vibration may cause temporary or permanent physical injury, particularly to the hands, arms and shoulders. To reduce the risk of vibration-related injury:

- Anyone using vibrating tools regularly or for an extended period should first be examined by a doctor and then have regular medical check-ups to ensure medical problems are not being caused or worsened from use. Pregnant women or people who have impaired blood circulation to the hand, past hand injuries, nervous system disorders, diabetes, or Raynaud's Disease should not use this tool. If you feel any medical or physical symptoms related to vibration (such as tingling, numbness, and white or blue fingers), seek medical advice as soon as possible
- Do not smoke during use. Nicotine reduces the blood supply to the hands and fingers, increasing the risk of vibration-related injury.
- Use tools with the lowest vibration when there is a choice between different processes.
- Include vibration-free periods each day of work.
- Let the tool do the work.
- To reduce vibration, maintain the tool as explained in this manual. If any abnormal vibration occurs, stop use immediately.

**SAVE ALL WARNINGS AND INSTRUCTIONS FOR FUTURE REFERENCE**

## UNPACKING

### Refer to Figure 1

- Check for shipping damage. Check immediately whether all parts and accessories are included. The bench buffer itself comes assembled as one unit. Additional parts (listed below) which need to be fastened to bench buffer, should be located and accounted for before assembling.
- The following items are included with your bench buffer:

Item	Description	Qty.
A	Spacers	2
B	Flanges	4
C	Hard Wheel	1
D	Soft Wheel	1
E	Brass Colored (Left Handed) M12 Nut	1
F	Silvered Colored (Right Handed) M12 Nut	1

Figure 1

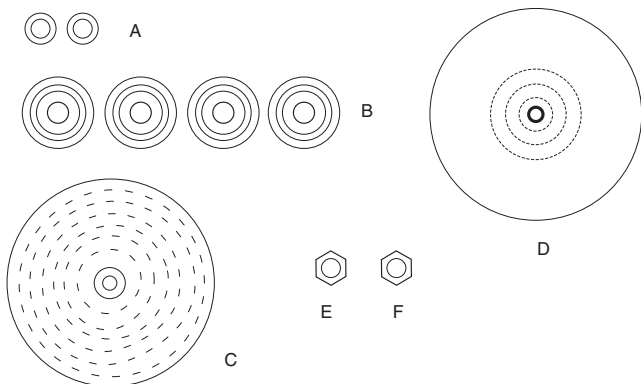

- Carefully remove the tool and any accessories from the box.
- Make sure that all items listed in the packing list are included.
- Inspect the tool carefully to make sure no breakage or damage occurred during shipping. Do not discard the packing material until you have carefully inspected and satisfactorily operated the tool.

### CAUTION

Do not attempt assembly if parts are missing. Call the Customer service line to obtain replacement parts.

### WARNING

Do not operate bench buffer, until completely assembled. Do not operate this tool until you have completely read and understood this manual.

### WARNING

To avoid injury, make sure all parts are assembled and adjusted properly before plugging the bench buffer into a power outlet and turning it ON.

## TOOLS NEEDED

You will need the following tools to assemble and adjust the machine. (The tools are not included.)

19 mm wrench or adjustable wrench

## SET UP

### WARNING

**Always place the ON/OFF switch in the OFF position and unplug the power cord from its power source before performing any assembly or adjustment.**

Failure to do so could result in accidental starting resulting in possible serious personal injury.

### WARNING

**To prevent serious injury from accessory failure. Do not use grinding wheels or other unintended accessories with this bench buffer.**

1. Slide a spacer onto the rotor shaft.
2. Slide a flange onto the rotor shaft with the flat side against the spacer.
3. Slide the buffing wheel onto the rotor up against the inner wheel flange.
4. Slide another wheel flange onto the rotor with the cupped surface sitting flat against the buffing wheel.

**NOTE:** "Right" and "left" are as seen from in front of the bench buffer, facing the switch.

5. Use the silver colored M12 nut to secure the buffing wheel to the right side, tighten nut securely.

Use the brass-colored (reverse thread) M12 nut to secure the buffing wheel to the left side, tighten nut securely.

Figure 2

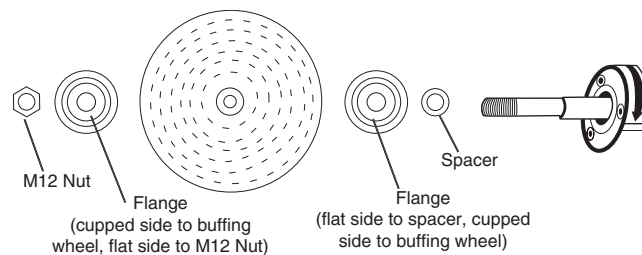

6. Apply the desired polishing compound (hard or soft, neither included) onto the buffing wheel(s) to be used.
7. Practice on a sample workpiece before buffing the actual workpiece. Good buffing results require experience.

## POWER SOURCE

### **▲ WARNING**

Do not connect to the power source until the machine is completely assembled.

The machine is wired for 120 volts, 60 HZ alternating current. Before connecting the machine to the power source, make sure the switch is in the "OFF" position. Running the unit on voltages which are not within range may cause overheating and motor burn-out. Heavy loads require that voltage at motor terminals be no less than the voltage specified on nameplate.

## GROUNDING INSTRUCTIONS

### **▲ WARNING**

Improper connection of equipment grounding conductor can result in the risk of electrical shock.

- The machine should be grounded while in use to protect operator from electrical shock.
- In the event of an electrical short circuit, grounding reduces the risk of electrical shock by providing an escape wire for the electric current.
- This machine is equipped with an approved 3-conductor cord rated at 120V and a 3-prong grounding type plug for your protection against shock hazards.
- Grounding plug should be plugged directly into a properly installed and grounded 3-prong grounding-type receptacle, as shown (Figure 3).

**Figure 3**

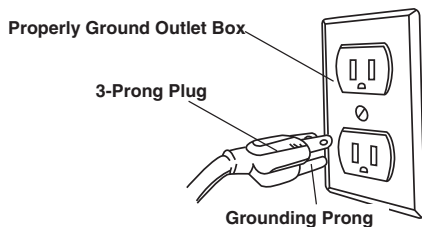

- The plug must be plugged into an outlet that is properly installed and grounded in accordance with all local codes and ordinances.
- Check with a qualified electrician or service personnel if these instructions are not completely understood or if in doubt as to whether the tool is properly grounded.
- Do not modify plug provided. If it will not fit in outlet, have a proper outlet installed by a qualified electrician. Use only 3-wire extension cords, that have 3-prong grounding type plugs and matching 3-conductor receptacles that accept the machine's plug, as show in Figure 3.

### **▲ WARNING**

Do not permit fingers to touch the terminals of plug when installing or removing from outlet.

- Inspect tool cords periodically, and if damaged, have it repaired by an authorized service facility.
- The conductor with insulation having an outer surface that is green with or without yellow stripes is the equipment-grounding conductor. If repair or replacement of the electric cord or plug is necessary, do not connect the green (or green and yellow) wire to a live terminal.
- A temporary 3-prong to 2-prong grounding adapter (see Figure 4) may be used to connect this plug to a matching 2-conductor receptacle as shown in figure 8. The temporary adapter should be used only until a properly grounded outlet can be installed by a qualified electrician.

**Figure 4**

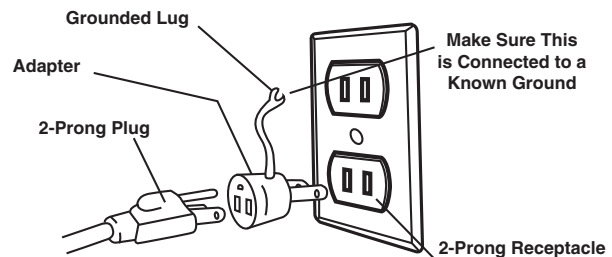

In Canada, the use of temporary adapter is not permitted by the Canadian Electric Code. Where permitted, the rigid green tab or terminal on the side of the adapter must be securely connected to a permanent electrical ground such as a properly grounded water pipe, a properly grounded outlet box or a properly grounded wire system.

- Many cover plate screws, water pipes and outlet boxes are not properly grounded. To ensure proper grounding means that it must be tested by a qualified electrician.

## EXTENSION CORDS

Use proper extension cords. Make sure the extension cord is in good condition. Use only 3-wire extension cords that have 3-prong grounding type plugs and 3-pole receptacles which accept the tool plug. When using an extension cord, make sure to use one heavy enough to carry the current of the machine. An undersized cord will cause a drop in the voltage, resulting in loss of power and overheating. Use the table to determine the minimum wire size (A.W.G.) Extension cord.

### Extension Cord Length

Wire Size.....	A.W.G.
Up to 25 ft.....	16 gauge

**NOTE:** Using extension cords over 25 ft. long is not recommended.



## OPERATION



The following section is designed to give instructions on the basic operations of this bench buffer.

### CAUTION

To avoid kickback and other hazards, only buff on the lower quarter of the wheel. Note the directional arrows on the front of the bench buffer.

### BASIC OPERATION

1. Make sure the ON/OFF switch is in the OFF position, then plug in the tool.

Figure 5

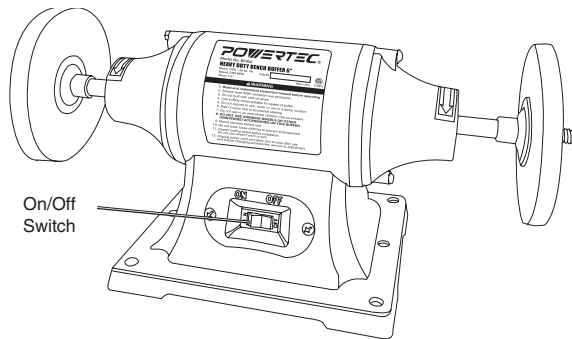

2. Place the ON/OFF switch in the ON position to turn on the unit.
3. Using two hands, firmly hold the workpiece and gently move it into contact with the buffing wheel.
4. Move the workpiece with the direction of the wheel, using a medium to hard pressure.

**NOTE:** The correct pressure must be applied to the workpiece to provide the best finish. Too little pressure will result in no significant change in the workpiece. Too much pressure may slow down the action of the buffing wheel and cause uneven marks on the workpiece.

5. Every few minutes, check the condition and wear of the buffing wheels. Replace a buffing wheel when it is worn or damaged.
6. When buffing is finished, remove the workpiece from the buffing wheel before turning bench buffer OFF.



## MAINTENANCE



### WARNING

**Always place the ON/OFF switch in the OFF position and unplug the power cord from its power source before performing any assembly or adjustment.**

Failure to do so could result in accidental starting resulting in possible serious personal injury.

### WARNING

To prevent serious injury from tool failure, do not use damaged equipment. If abnormal noise or vibration occurs, have the problem corrected before further use.

### GENERAL MAINTENANCE

### WARNING

Repairs to the bench buffer should be performed by trained personnel only. Unauthorized repairs or replacement with non-factory parts could cause serious injury to the operator and damage to the bench buffer.

### WARNING

If the supply cord of this power tool is damaged, have it replaced by a qualified service technician.

Before each use, inspect the general condition of the tool. Check for:

- loose hardware,
- misalignment or binding of moving parts,
- cracked or broken parts,
- damaged electrical wiring, and
- any other condition that may affect its safe operation

### CLEANING

After each use, wipe external surfaces of the tool with a clean cloth.

Hand wash the buffing wheels using mild detergents, air dry. If a buffing wheel has become too hard, use a stiff wire brush (not included) to fluff it up.

Do not immerse any part of the tool in liquid.

### WARNING

Periodically blow dirt and dust out of all air vents with clean, dry air. To minimize the risk of eye injury, always wear ANSI approved eye protection and NIOSH approved breathing protection when performing this.



6



## TROUBLESHOOTING

SYMPTOM	POSSIBLE CAUSE(S)	CORRECTIVE ACTION
Motor does not run.	<ol style="list-style-type: none"> <li>1. Machine not plugged in.</li> <li>2. Power switch in OFF position.</li> <li>3. Power cord is faulty.</li> <li>4. Fuses or circuit breaker is open.</li> </ol>	<ol style="list-style-type: none"> <li>1. Plug power cord into electrical receptacle.</li> <li>2. Place ON/OFF switch to ON position.</li> <li>3. Replace power cord.</li> <li>4. Overloaded electrical circuit.</li> </ol>
Motor stalls or runs slow.	Undersized or excessive length of extension cord.	Use correct size.
Decreased performance	Accessory is dull or damaged	Replace accessory, always use sharp accessories.
Motor runs hot	<ol style="list-style-type: none"> <li>1. Motor is overloaded.</li> <li>2. Poor air circulation around motor.</li> <li>3. Accessory is dull or damaged</li> <li>4. Undersized or excessive length of extension cord.</li> </ol>	<ol style="list-style-type: none"> <li>1. Reduce pressure on workpiece.</li> <li>2. Remove any blockage around motor.</li> <li>3. Replace accessory, always use sharp accessories.</li> <li>4. Use correct size.</li> </ol>
Fuse blows or circuit breaker trips.	<ol style="list-style-type: none"> <li>1. Motor is overloaded.</li> <li>2. Overloaded electrical circuit breaker.</li> <li>3. Wrong fuse or circuit breaker</li> <li>4. Defective cord, plug or switch creating a short circuit.</li> <li>5. Undersized or excessive length of extension cord.</li> </ol>	<ol style="list-style-type: none"> <li>1. Reduce pressure on workpiece.</li> <li>2. Reduce the amount of items on circuit</li> <li>3. Replace with correct fuse or circuit breaker.</li> <li>4. Replace with new parts</li> <li>5. Use correct size.</li> </ol>



**NOTE**



# 8 6" HEAVY DUTY BENCH BUFFER PARTS ILLUSTRATION

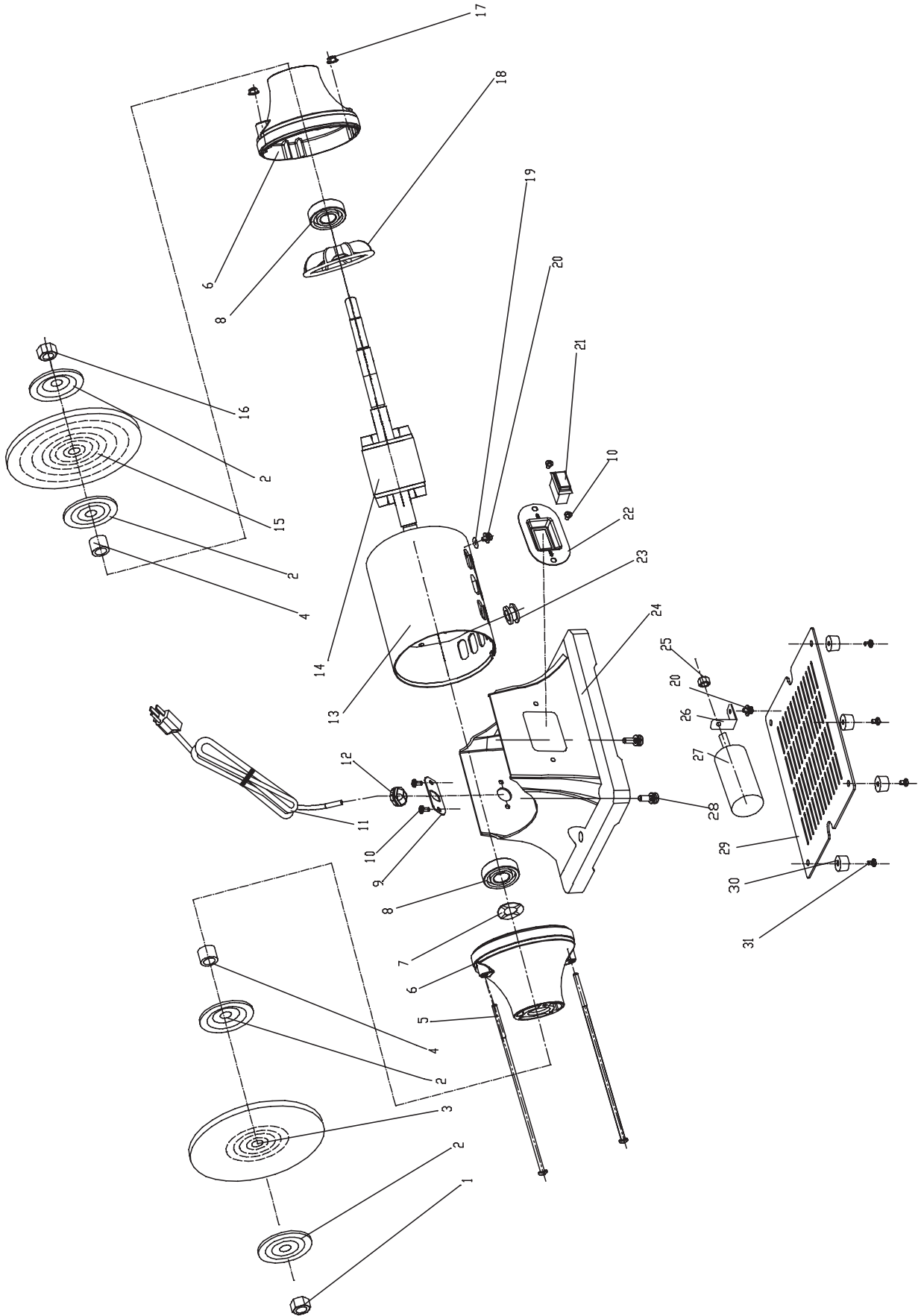

# 6" HEAVY DUTY BENCH BUFFER PARTS LIST



PARTS LIST

Key No.	Part #	Description	Specification	Qty.	Key No.	Part #	Description	Specification	Qty.
1	BF600001	I type hex nut	M12 left	1	18	BF600018	Fan		1
2	BF600002	Flange		4	19	BF600019	Outer toothed locking washer	D4	1
3	BF600003	Soft buffering wheel		1	20	BF600020	Philips screw+spring washer+flat washer	M4x8	2
4	BF600004	Spacer		2	21	BF600021	Switch		1
5	BF600005	Philips screw+flat washer	M5x200	2	22	BF600022	Switch plate		1
6	BF600006	End bell		2	23	BF600023	Cord bushing		1
7	BF600007	Waving spring washer	D35	1	24	BF600024	Base		1
8	BF600008	Bearing	6202	2	25	BF600025	I type nut	M8	1
9	BF600009	Cord clamp plate		1	26	BF600026	Capacitor support		1
10	BF600010	Philips screw	M5X8	4	27	BF600027	Capacitor		1
11	BF600011	Power cord with plug		1	28	BF600028	Philips scrwe+spring washer	M6x20	2
12	BF600012	Cord clamp		1	29	BF600029	Base bottom plate		1
13	BF600013	Stator		1	30	BF600030	Rubber feet		4
14	BF600014	Rotor		1	31	BF600031	Philips screw+flat washer	M4x12	4
15	BF600015	Hard buffing wheel		1					
16	BF600016	I type hex nut	M12	1					
17	BF600017	Hex flange nut	M5	2					



9



## WARRANTY

Thank you for investing in a **POWERTEC** power tool. This product has been designed and manufactured to meet high quality standards and is guaranteed for domestic use against defects in workmanship or material for a period of 12 months from the date of purchase. This guarantee does not affect your statutory rights.

### **SOUTHERN TECHNOLOGIES LLC. BENCH TOP AND STATIONARY POWER TOOL LIMITED 1 YEAR WARRANTY AND 30-DAY SATISFACTION GUARANTEE POLICY**

**POWERTEC** products are designed and manufactured by **Southern Technologies LLC**. All warranty communications should be directed to **Southern Technologies LLC** by calling 847-780-6120, 9 AM to 5 PM, Monday through Friday, US Central Time.

#### **30- DAY SATISFACTION GUARANTEE POLICY**

During the first 30 days after the date of purchase, if you are dissatisfied with the performance of this **POWERTEC** tool for any reason, you may return the tool to the retailer from which it was purchased for a full refund or exchange. You must present proof of purchase and return all original equipment packaged with the original product. The replacement tool will be covered by the limited warranty for the balance of the one year warranty period.

#### **LIMITED ONE YEAR WARRANTY**

This warranty covers all defects in workmanship or materials in this **POWERTEC** tool for a one year period from the date of purchase. This warranty is specific to this tool. **Southern Technologies, LLC** reserves the right to repair or replace the defective tool, at its discretion.

#### **HOW TO OBTAIN SERVICE**

To obtain service for this **POWERTEC** tool you must return it, freight prepaid, to **POWERTEC**. You may call 847-780-6120 for more information. When requesting warranty service, you must present the proof of purchase documentation, which includes a date of purchase. **POWERTEC** will either repair or replace any defective part, at our option at no charge to you. The repaired or replacement unit will be covered by the same limited warranty for the balance of one year warranty period.

#### **WHAT IS NOT COVERED**

This warranty applies to the original purchaser at retailer and may not be transferred.

This warranty does not cover consumable items such as saw blades, knives, belts, discs, cooling blocks and sleeves. This warranty does not cover required service and part replacement resulting from normal wear and tear, including accessory wear.

This warranty does not cover any malfunction, failure or defect resulting from:

- 1) misuse, abuse, neglect and mishandling not in accordance with the owner's manual.
- 2) damage due to accidents, natural disasters, power outage, or power overload.
- 3) commercial or rental use.
- 4) alteration, modification or repair performed by persons not recommended by **POWERTEC**.

#### **DISCLAIMER**

To the extent permitted by applicable law, all implied warranties, including warranties of **MERCHANTABILITY** or **FITNESS FOR A PARTICULAR PURPOSE**, are disclaimed. Any implied warranties, that cannot be disclaimed under state law are limited to one year from the date of purchase. **Southern Technologies LLC**. is not responsible for direct, indirect, incidental or consequential damages. Some states do not allow limitations on how long an implied warranty lasts and/or do not allow the exclusion or limitation of incidental or consequential damages, so the above limitations may not apply to you. This warranty gives you specific legal rights, and you may also have other rights which vary from state to state. **Southern Technologies LLC**., makes no warranties, representations, or promises as to the quality or performance of its power tools other than those specifically stated in this warranty.

**NOTE**

**NOTE**

**NOTE**



***POWERTEC***<sup>®</sup>

Southern Technologies, LLC  
3816 Hawthron CT,  
Waukegan, IL 60087