

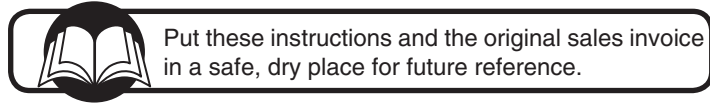

6' Heavy Duty Barn Door Hardware Kit



Visit us on the web at southerntechllc.com



UNPACKING

Refer to Figure 1

- Examine shipping carton for freight damage before opening. If shipping carton is damaged file a claim with the carrier immediately.
- Carefully remove all contents from shipping carton. The shipping carton contains:

Figure 1

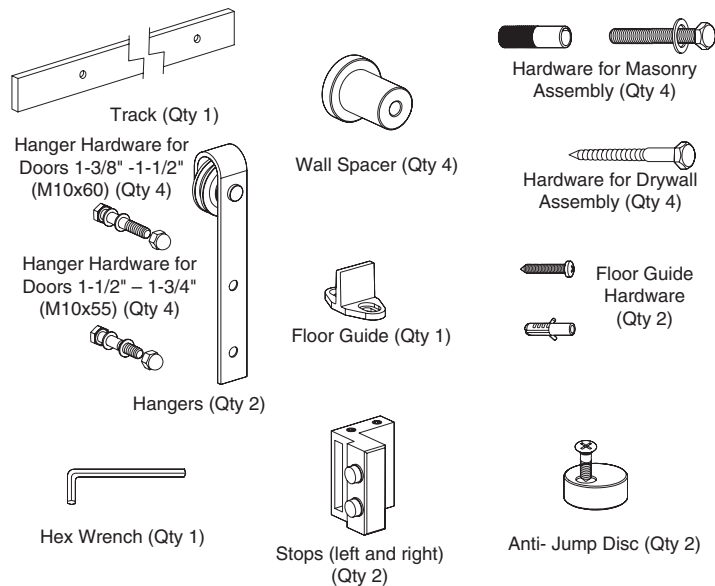

NOTE: Contact the customer service center if any of these parts are missing.

NOTE: After unit is assembled dispose of all packaging material in an environmentally safe way.

IMPORTANT: Low ceilings or crown molding could interfere with the installation of this kit. There **MUST** be a minimum clearance of 6" above the top of the door for the kit to work correctly.

IMPORTANT: Depending on the thickness of your door, trim or molding around the opening could interfere with the installation. The issue can be corrected by adding a header as described in Step 6.

INSTALLATION

TOOLS NEEDED

- Phillips Screwdriver
- 13 mm wrench or socket
- 16 mm wrench
- 17 mm wrench or two adjustable wrenches,
- 13/32" drill bit

- 25/64" masonry bit (for masonry installation only)
- 1/4" Drill Bit
- Tape Measure
- Level
- Drill
- Carpenters Pencil

Figure 2

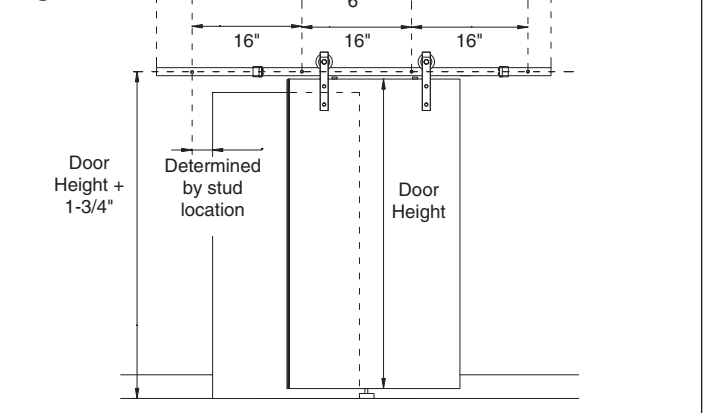

1. Prepare the door to use the floor guide: Mortise a groove 1/4" wide by 3/4" deep into the center of the bottom of the door edge.

Figure 3

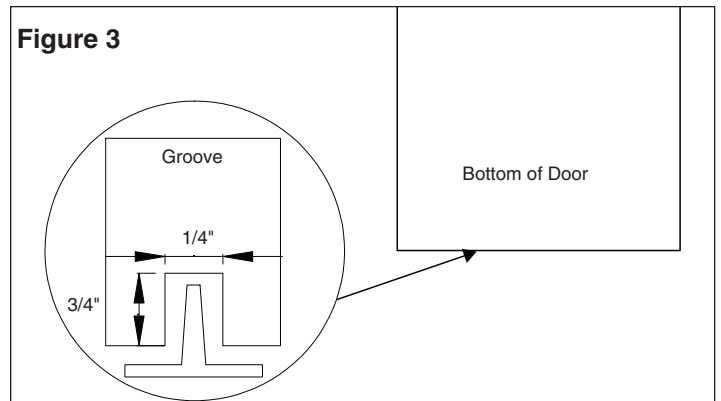

2. Install hangers: Use the hangers as a template to pre-drill holes through the door.
3. Position the hangers on the front center of the stiles or a minimum of 2" from the edge of the door and 1-7/8" from the bottom of the wheel and the top of the door. Mark the holes to be drilled. **NOTE:** A 1-7/8" set block can be cut and placed between the wheel and door top to help prevent movement while drilling the holes.
4. Drill the holes into the door, using a 13/32" drill bit, and assemble the hardware supplied. **NOTE:** Two sets of hardware are supplied choose the correct hardware for the door thickness.

Figure 4

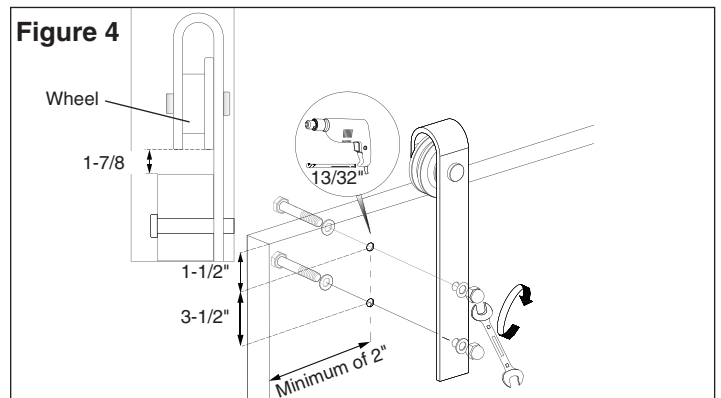

5. Position the anti-jump disc at least 1" from the edge of the hangers and fasten to the front edge of the door. Do not tighten completely, they will need to be rotated into place and tightened later.

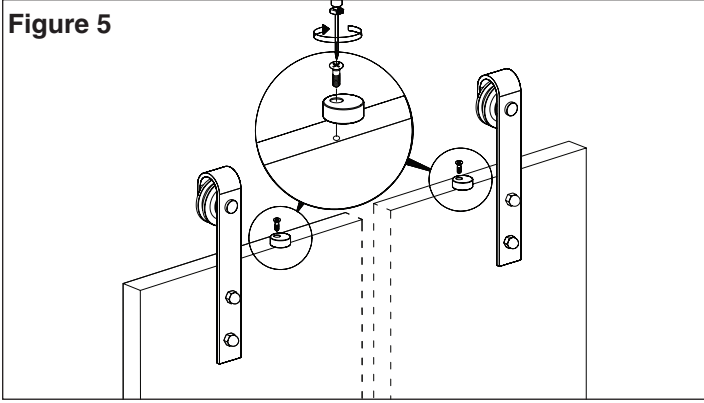

6. **IMPORTANT:** The track has pre-drilled holes 16" on center, check your specific layout requirement, if the holes do not align with wall studs a 1 x 4" or 1 x 6" header board **MUST** be installed directly over the door opening into the studs. The header board **MUST** measure the length of the track or longer. **NOTE:** Hardware is supplied for attaching track to masonry or drywall, use the correct hardware.

- a. Slide the left and right stops onto the track, the stops should be inside the first and last hole on the track. **NOTE:** Check your specific layout for the stop placement, if the layout requires the stop to be mounted outside of the first and last holes they will be mounted last.
- b. Measure the door height plus 1-3/4" up from the floor, based on the location of the studs, determine the left or right starting point for your track. Position the track and use it as a template to mark and drill the pilot holes into the header board/studs or masonry wall. Assemble the spacer between the track and the wall, fasten with six lag bolts supplied for drywall or anchors and bolts for masonry wall. **NOTE:** Assemble the two ends first and use a level to insure the track is level.

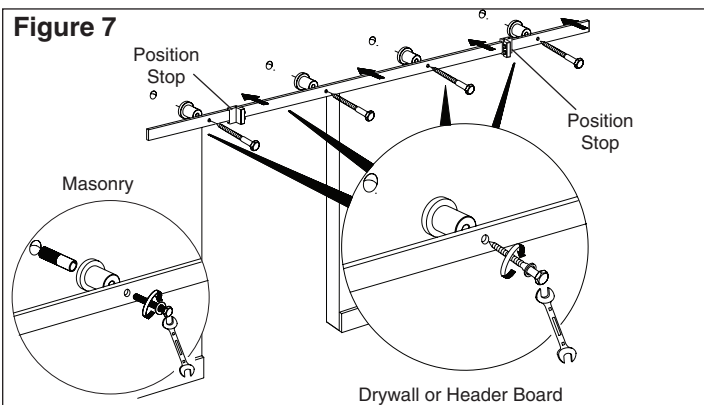
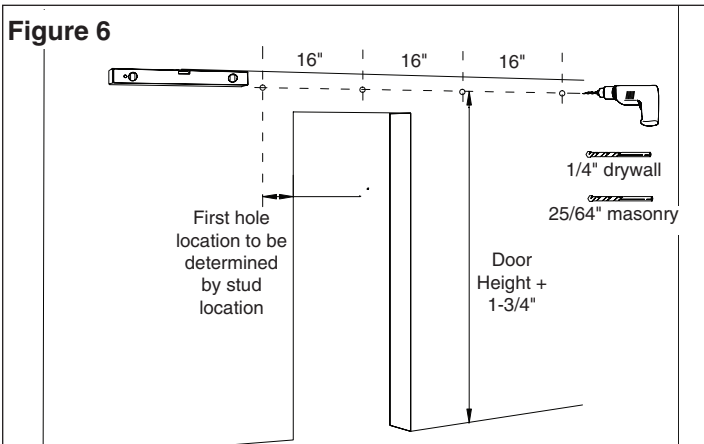

7. Place the door onto the track. Tighten the anti-jump disc under the track and tighten (Figure 8).

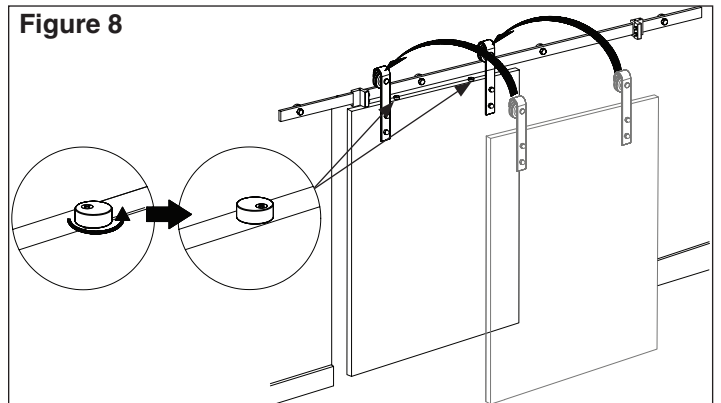

8. Position the floor guide close to the door opening, make sure the door tracks correctly. Mark and drill holes, secure with hardware supplied. **NOTE:** Anchors are supplied if drilling into concrete.

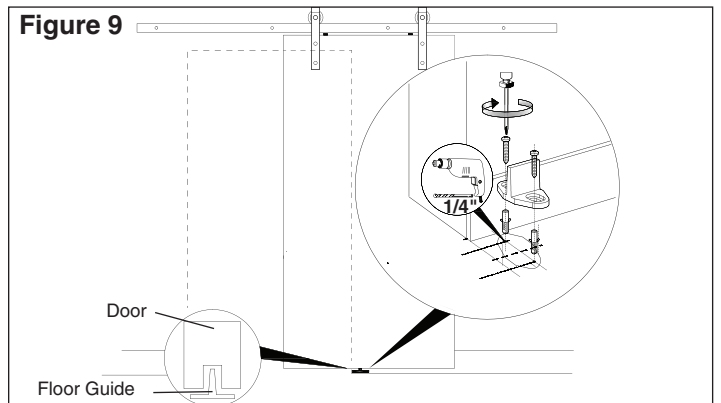

9. Slide the door open and closed to make sure it operates smoothly. Secure the left and right stops at the desired location.

