

POWERTEC®

8" Vacuum Suction Cup

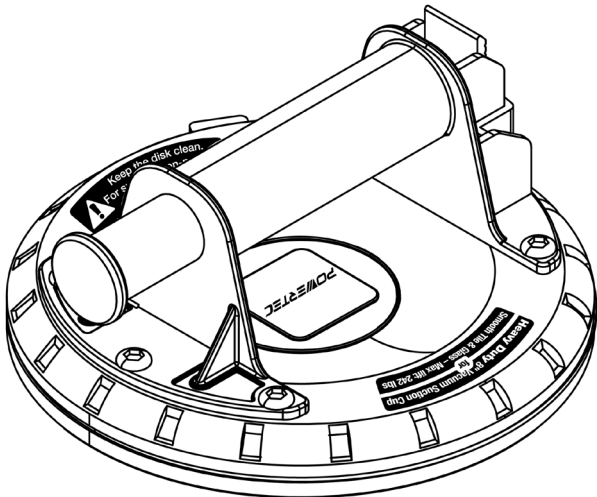

The **POWERTEC 71884 Vacuum Suction Cup** is designed for lifting and moving glass, tile and any other material that has a smooth, flat and non-porous surface.

WARNING

Risk of serious personal injury. This product is not designed or intended for climbing or securing people in any way. Using this product for climbing or any other unintended purpose may result in serious personal injury.

WARNING

Risk of personal injury. For your own safety, read all of the rules and precautions before operating tool.

CAUTION

This product was designed to be used as a carrying aid for tile and slabs and for installing material. Do not overload. Maximum horizontal lifting capacity is **242 lbs (110 kg)**.

WARNING

Always follow proper operating procedures as defined in this instruction manual even if you are familiar with use of this Vacuum Suction Cup or any tool used with this Vacuum Suction Cup. Remember that being careless for even a fraction of a second can result in severe personal injury. You must be familiar with the use of any tool or accessory used with this Vacuum Suction Cup. The supplier cannot be held responsible for any accident, injury or damage incurred while using this Vacuum Suction Cup with any tool.

WARNING

Do not modify this Vacuum Suction Cup and/or use it for any application other than that for which it was designed.

FOLLOW ALL STANDARD SAFETY PRECAUTIONS, INCLUDING:

- Keep children and visitors at a safe distance from work area.
- Wear proper apparel.
- Wear hard hat for overhead work and installations.
- Wear safety shoes with non-slip soles.

Read the
Instruction Manual

Wear Safety Gloves

Wear Protective
Footwear



- Be alert and think clearly. Never operate power tools when tired, intoxicated or when taking medications that cause drowsiness.
- Use the right tool for the job. Do not force the tool to do a job for which it was not designed.

CAUTION

Think safety! Safety is a combination of operator common sense and alertness at all times when tools are being used.

SPECIFIC SAFETY WARNINGS

WARNING

Risk of personal injury. Read and understand this entire instruction manual and the operating manual of any tool being used with this Vacuum Suction Cup.

- **NEVER use for overhead suspension.** Object may detach and drop unexpectedly causing serious personal injury or damage to property.
- **DO NOT** use sharp objects to release Vacuum Suction Cup from surface as this will damage the suction pad.

**Save all warnings and instructions
for future reference**

CONTENTS

ITEM	DESCRIPTION	QTY
A	8" Vacuum Suction Cup	1
B	Protective Cover	1
C	Fabric Filter (replacement)	1
D	Air Diaphragm (replacement)	1
E	Air Seal (replacement)	1
F	Maintenance Tool	1
G	Carry Case	1

Figure 1

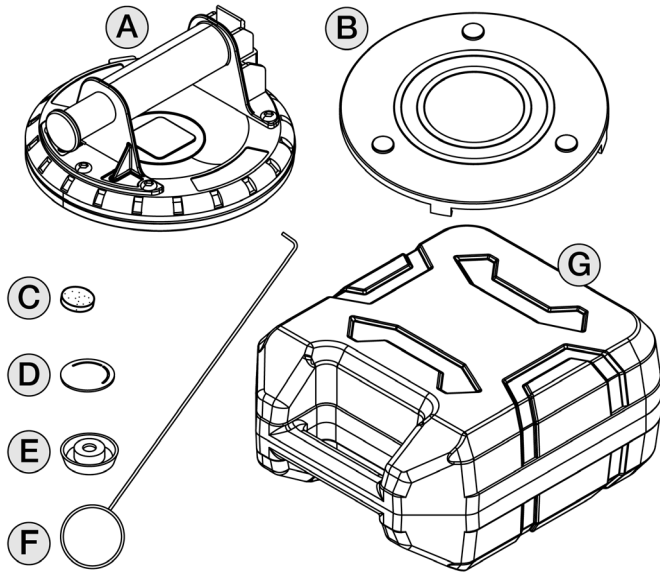

OPERATION

WARNING

Risk of serious personal injury. This product is not designed or intended for climbing or securing people in any way. Using this product for climbing or any other unintended purpose may result in serious personal injury.

WARNING

This product was designed to be used as a carrying aid for heavy tile and slabs. Do not overload. The maximum horizontal lifting capacity is 242 lbs (110 kg).

Operational Features: Top View

Figure 2

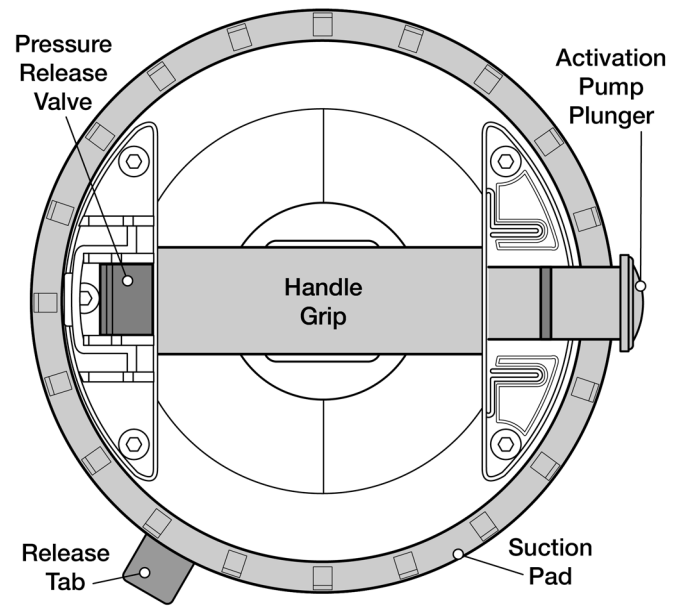

Suction Pad Features: Bottom View

Figure 3

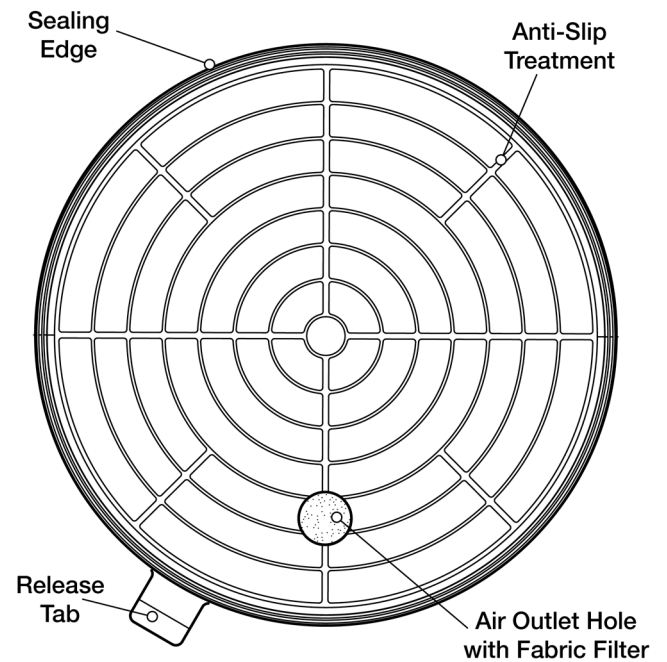

Vacuum Suction Cup Precautions:

WARNING

Risk of serious injury or material damage. NEVER touch or bump the Release Valve while lifting.

NOTE: Ensure Vacuum Suction Cup surface is clean and in good shape. Check for staining, deformation, tears or debris before placement.

- Keep the air outlet in the rubber pad free from dust, water or liquid.
- Make sure the rubber suction pad is clean before use.
- Use on clean, dry, smooth, nonporous material, without moisture or contaminants on the surface.
- Temperature limits from 10° to 120° F (-12° to 49° C.)

Activate the Vacuum Suction Cup:

- Place the Vacuum Suction Cup on the material to be carried.

NOTE: Position Suction Cup onto material surface so the RED LINE will be noticeable if it appears while lifting.

- While holding Suction Cup against the material, manually pump the plunger until Suction Cup is properly engaged.

NOTE: When the RED LINE recedes, vacuum is sufficient for lifting.

- Before lifting, make sure vacuum is sufficient for lifting and the Suction Cup adheres to the material surface securely.

NOTE: Check plunger frequently to ensure Suction Cup remains securely attached. If the RED LINE appears while lifting, immediately set down the load and pump plunger until RED LINE recedes again (see WARNINGS).

Figure 4

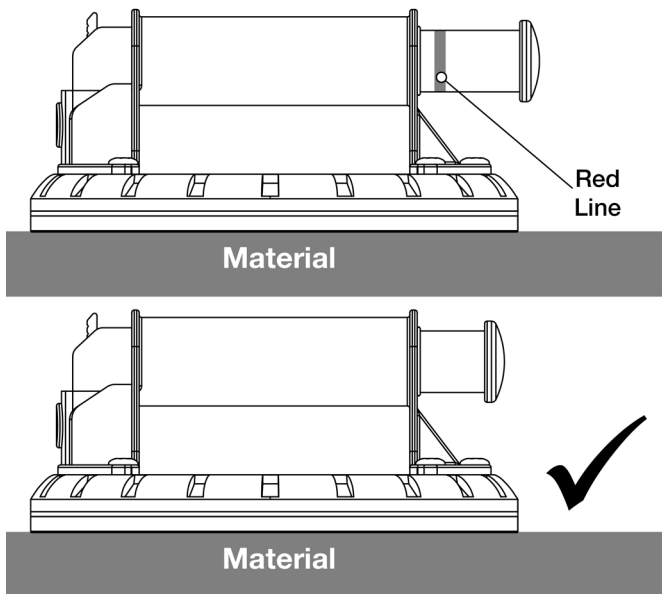

Suction Release Valve/Button:

- After placing load in desired location manually push the Pressure Release Valve until the Suction Cup disengages.
- Remove and store Suction Cups when not in use.

Figure 5

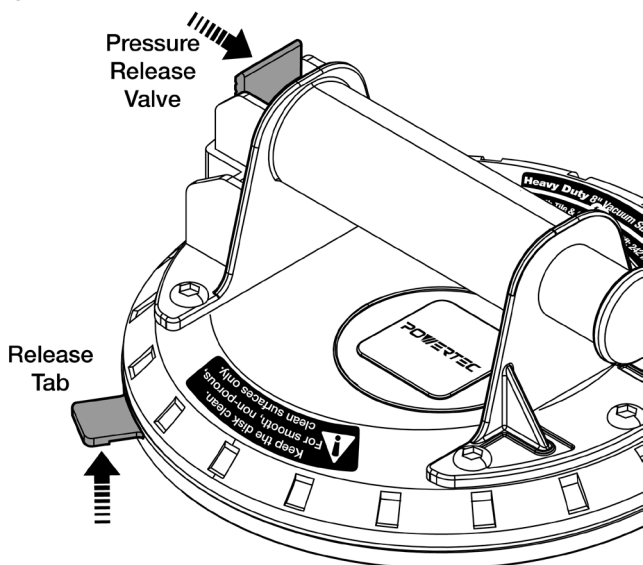

NOTE: If Pressure Release Valve does not activate, pull Release Tab on suction pad to break the seal and release the material.

Protect the Suction Cup:

- Clean Suction Cup with a clean and dry cloth after every use.
- Cover Suction Cup with Protective Cover (B) when not in use or during storage.

Figure 6

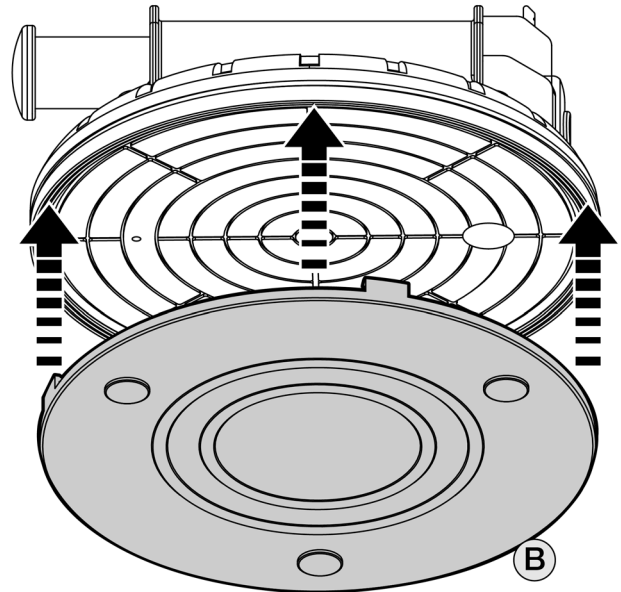

INSPECTION

Examine and test Suction Cup regularly to make sure it does not exhibit any of the following faults:

- Cuts or damage to sealing edge of rubber pad.
- Cracks or dents in handle or pump plunger.
- Reappearance of red line soon after attaching Suction Cup.
- Sluggishness or dramatic changes in pump action.
- Excessive glaze or stiffness of rubber pad.

STORAGE

- Clean rubber pad with a soft cloth after every use.
- Keep Suction Cup clean and dry. Cover Suction Cup with Protective Cover, and store in carry case.

⚠ WARNING

Risk of serious personal injury. Failure to observe WARNINGS could cause injury to the user, damage the Suction Cup or the load.

- Do not use the Suction Cup to lift loads that exceed the Maximum Load Capacity or the effective capacity.
- Do not use the Suction Cup to support a person.
- Do not place the Suction Cup face against surfaces which could damage the sealing edges.
- Avoid conditions that could cause the Suction Cup to slip or to disengage prematurely, such as: contaminants, cuts or scratches in the Suction Cup face or contact surface; applying the Suction Cup to porous materials; or applying pressure against the Suction Cup edge.
- Do not allow anything to interfere with free movement of the plunger while the Suction Cup is attached.
- Do not touch release tab while lifting.
- Do not use harsh chemicals (such as solvents or gasoline) or inappropriate rubber cleaners and conditioners to clean the Suction Cup.

MAINTENANCE

If Dust or Water Enters Pump Chamber:

Figure 7

- Push Pressure Release Valve and slowly pull out plunger.

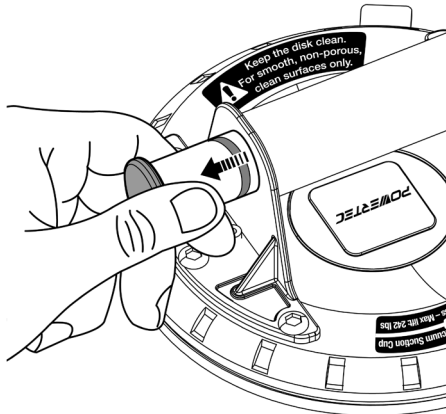

Figure 8

- Wrap a clean cloth around your finger or Maintenance Tool (F) to clean pump chamber.

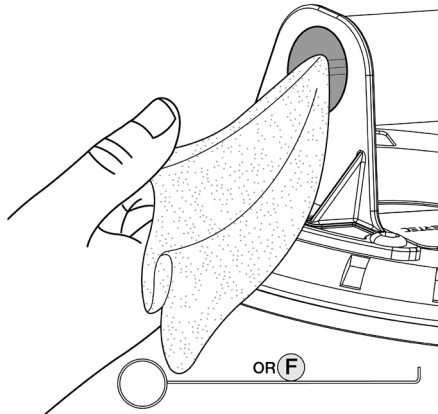

Figure 9

- After cleaning the plunger and pump chamber, appropriately apply a small amount of mechanical grease.
- Reinsert plunger into pump chamber.

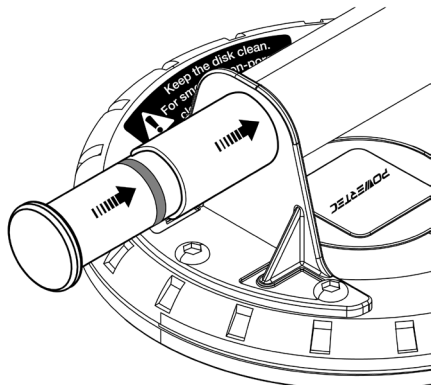
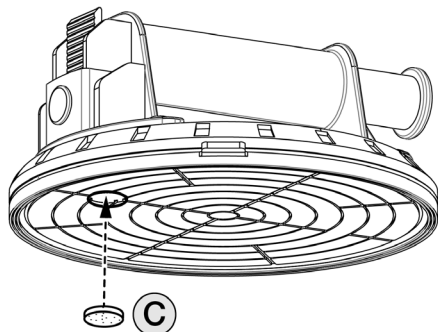

Figure 10

- When Foam filter is dirty or worn, replace with new Filter (C) (one replacement included).



If plunger does not pump, or Red Line will not recede, check Air Diaphragm and Air Seal—replace if damaged.

Figure 11

- Push Pressure Release Valve and slowly pull out plunger.
- Use Maintenance Tool (F) to fish out Rubber Washer and then Air Diaphragm.

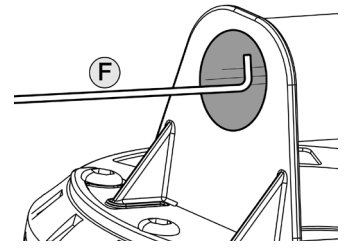

Figure 12

- Inspect Air Diaphragm. If damaged, replace with new Air Diaphragm (D) (one replacement included).
- Insert Air Diaphragm (D) and then Rubber Washer, ensure bumps on Rubber Washer are facing Air Diaphragm (D).

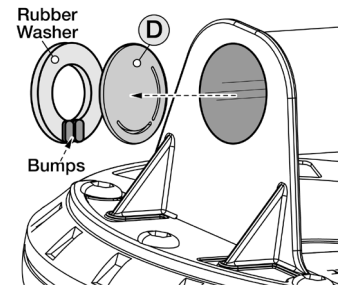
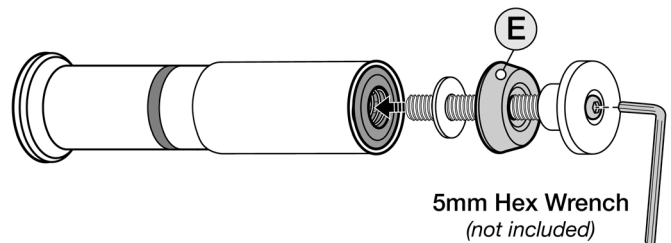

Figure 13

- Inspect Air Seal. If damaged, use 5mm hex wrench (not included) to remove the bolt from plunger. Replace with new Air Seal (E) (one replacement included).
- Insert new Air Seal (E) from large opening end, and then washer onto the bolt. Use 5mm hex wrench (not included) to thread the bolt with Air Seal and washer on plunger. Tighten the bolt to 88.5 lb-in.
- Clean the plunger and pump chamber, appropriately apply a small amount of mechanical grease.
- Reinsert plunger into pump chamber.



GENERAL MAINTENANCE

⚠ WARNING

Keep the Vacuum Suction Cup dry, clean, and free from oil and grease. Always use a clean cloth when cleaning. Never use brake fluids, gasoline, petroleum-based products or any strong solvent to clean the Vacuum Suction Cup. Chemicals can damage, weaken or destroy plastic which may result in serious personal injury.

Visit us on the web at www.powertecproducts.com



Put these instructions and the original sales invoice in a safe, dry place for future reference.

Southern Technologies, LLC • Chicago, IL 60606