

**Workbench Casters with Quick-Release Plates, 4 Sets**

This kit contains four Workbench Quick-Release Plates and one Powertec 17001 Workbench Caster Kit.

**NOTE:** The quick-release plates can be used with multiple sets of the Powertec 17001 Workbench Caster Kit or other compatible brands.

**PACKAGING CONTENTS**

- 4 - Quick-Release Plates
- 4 - Locking Pins
- 8 - Bolt 1/4"-20 x 2 (50.8 mm) long
- 8 - Washers
- 8 - Nuts
- 1 - 17001 Workbench Caster Kit
  - 4 - Pedal Bracket Assembly
  - 4 - Casters
  - 4 - Nuts
  - 4 - Lock Washers
  - 16 - Wood Screws

**ASSEMBLE THE QUICK-RELEASE PLATES AND WORKBENCH CASTERS**

- Make sure the stand is sitting on a flat stable surface.
- Measure and mark 2-1/2" (65.3 mm) from the floor to the center of the workbench leg. (Figure 1)
- Place the caster plate onto the workbench leg and align the bottom hole with the 2-1/2" (65.3 mm) mark. Mark the top hole [4" (101.6 mm)]. Remove caster plate and drill holes into workbench leg. Repeat on each leg. **NOTE:** If assembling several quick-release plates, a template can be created.
- Mount the caster plate to workbench leg with supplied hardware (bolt, washer, nut). Repeat on each leg. **NOTE:** If the workbench leg is larger than 1-1/2" (38.1 mm), longer bolts (not included) will be needed.

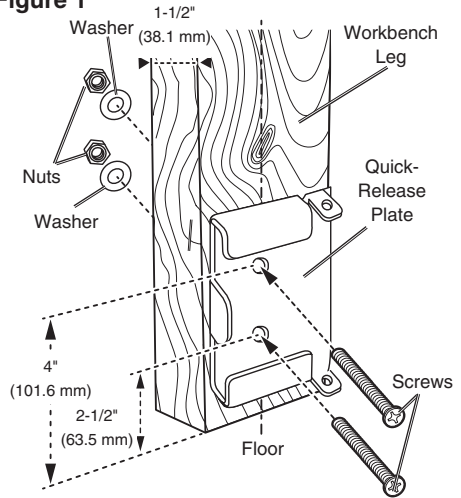
**Figure 1**

- Attach Caster to Pedal Bracket Assembly using Nut and Lock Washer provided. (Figure 2)

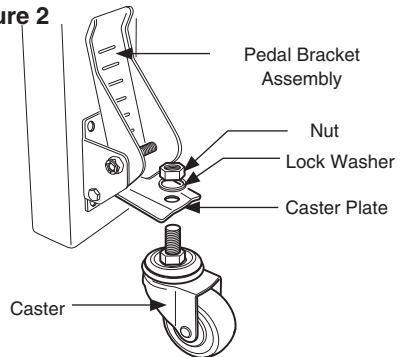
**Figure 2**

- With caster in the "up" position align to caster plate and slide into place, lock in place with locking pin. (Figure 3)

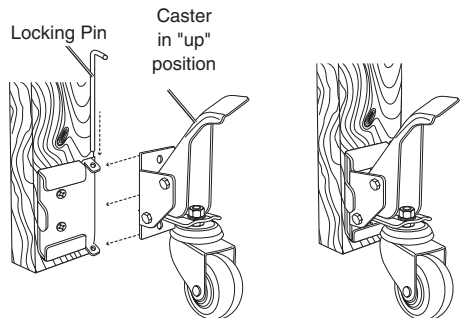
**Figure 3**

## TO USE



**PINCH HAZARD!** Always use feet to step on the caster levers.

- Step on the caster lever and the caster assembly will extend and lift the legs off the ground allowing the stand to be moved.
- To retract, use your foot to raise the caster lever and the caster assembly will "snap" up, lowering the leg.

## ALTERNATE ASSEMBLY

### To Assemble POWERTEC 17001 Workbench Caster Kit Without Using the Quick-Release Plates

1. **If using two screw assembly shown in Figure 4.**
  - a. Mark your drill points on the workbench leg at 2" (51 mm) and 4-3/4" (120 mm) from the bottom of the leg.
  - b. Drill two pilot holes on each workbench leg.
2. **If using four screw assembly shown in Figure 5.**
  - a. Mark your drill points on the workbench leg at 2" (51 mm) and 4-3/4" (120 mm) from the bottom of the leg.
  - b. Drill four pilot holes on each workbench leg.
3. Install Pedal Bracket Assembly to the workbench leg with Wood Screws provided. (Figure 4 and 5)
4. Attach Caster to Pedal Bracket Assembly using Nut and Lock Washer provided. (Figure 6)

**NOTE:** You may need to remove the caster from the Caster Plate to attach and secure the Pedal Bracket Assembly to the workbench leg.

### Other Installations

The workbench casters can be used on many different tables or stands other than workbenches. This includes router table stands, lathe stands or anywhere in your shop where you need mobility for a larger item. To install the casters on a metal stand, follow the instructions under **To Assemble POWERTEC 17001 Workbench Caster Kit Without Using the Quick-Release Plates** and replace the Wood Screws (provided) in step 2 with nuts, bolts and washers (not provided) to properly secure the Pedal Bracket Assembly as showing in Figure 7.

Figure 4

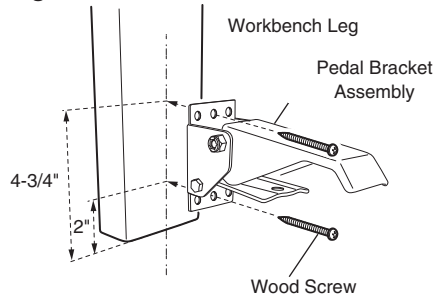

Figure 5

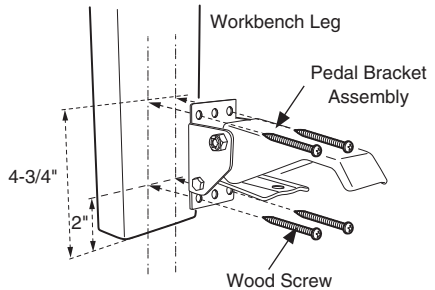

Figure 6

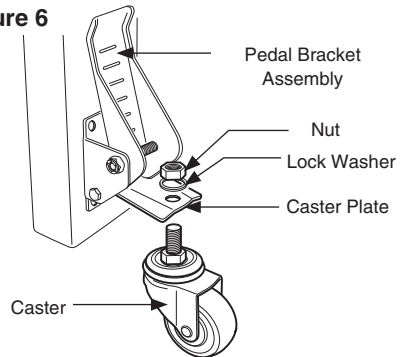
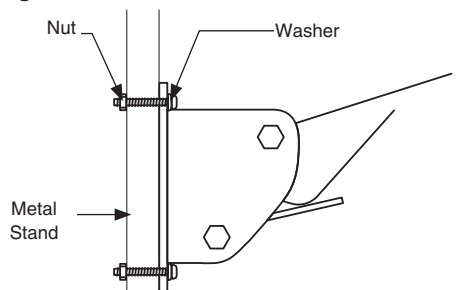

Figure 7



Visit us on the web at [powertecproducts.com](http://powertecproducts.com)



Put these instructions and the original sales invoice in a safe, dry place for future reference.

Southern Technologies, LLC  
Waukegan, IL 60087

18-0709