

**Workbench Caster Kit with Multi-Mounting Options (4 Sets)**

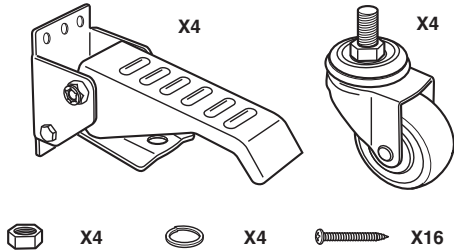

**UNPACKING**

You will need this manual for safety instructions, operating procedures, and warranty. Check for shipping damage. IMMEDIATELY CHECK AND MAKE SURE ALL PARTS AND ACCESSORIES ARE INCLUDED.



**ASSEMBLY**

1. If using two screw assembly shown in Figure 1.
  - a. Mark your drill points on the workbench leg at 2" (51 mm) and 4-3/4" (120 mm) from the bottom of the leg.
  - b. Drill two pilot holes on each workbench leg.
- If using four screw assembly shown in Figure 2.
  - c. Mark your drill points on the workbench leg at 2" (51 mm) and 4-3/4" (120 mm) from the bottom of the leg.
  - d. Drill four pilot holes on each workbench leg.
2. Install Pedal Bracket Assembly to the workbench leg with Wood Screws provided. (Figure 1 and 2)
3. Attach Caster to Pedal Bracket Assembly using Nut and Lock Washer provided. (Figure 3)

**NOTE:** You may need to remove the caster from the Caster Plate to attach and secure the Pedal Bracket Assembly to the workbench leg.

Figure 1

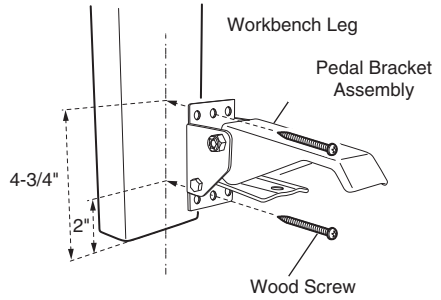

Figure 2

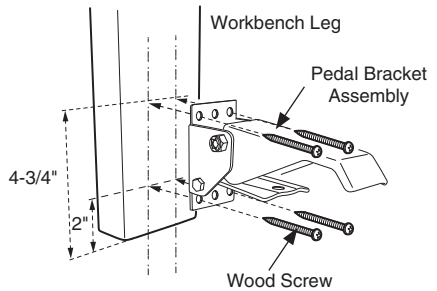
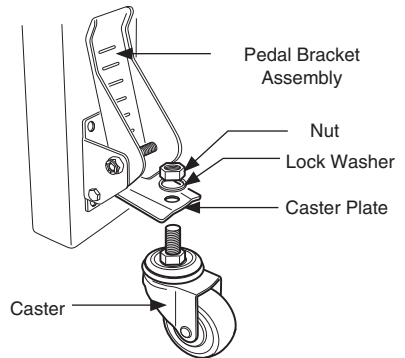

Figure 3



## Other Installations

The workbench casters can be used on many different tables or stands other than workbenches. This includes router table stands, lathe stands or anywhere in your shop where you need mobility for a larger item. To install the casters on a metal stand, follow the instructions under **Assembly** and replace the Wood Screws (provided) in step 2 with nuts, bolts and washers (not included) to properly secure the pedal bracket assembly as shown in Figure 4.

Figure 4

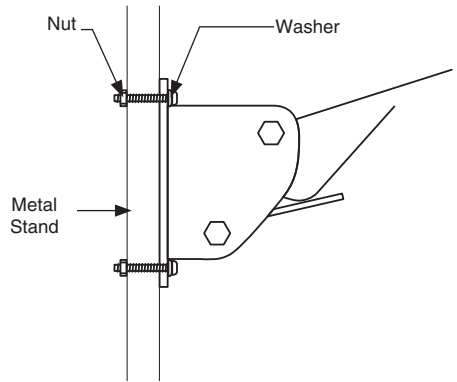

Visit us on the web at [powertecproducts.com](http://powertecproducts.com)



Put these instructions and the original sales invoice in a safe, dry place for future reference.

Southern Technologies, LLC  
Waukegan, IL 60087

18-0709